

**THK**

**NEW**



# Low Price Actuator

---

# VLA

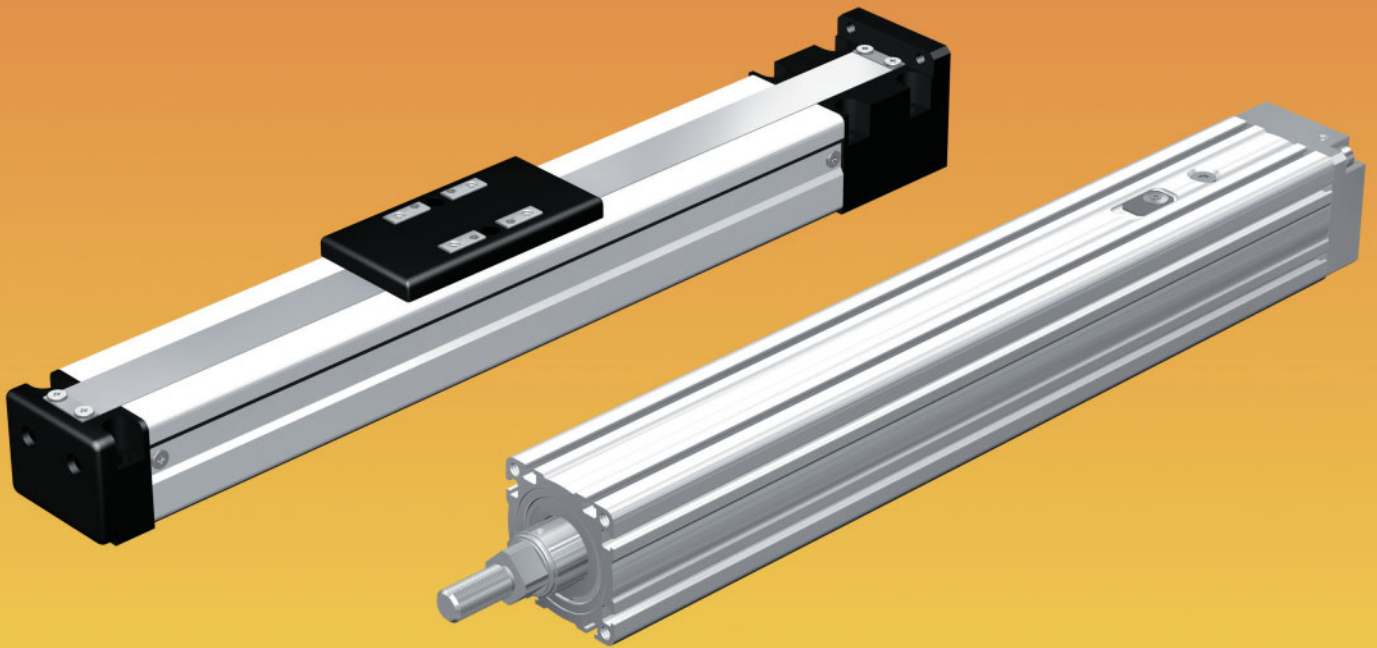

**THK CO., LTD.**  
TOKYO, JAPAN

CATALOG No.320-4E

# Low Price Actuator

## Two types of actuator are available.

Actuator Model VLA is offered in two types. You can select either type according to your service conditions.

### Slider Type: Model VLA-ST

#### Structural drawing of Model VLA-ST

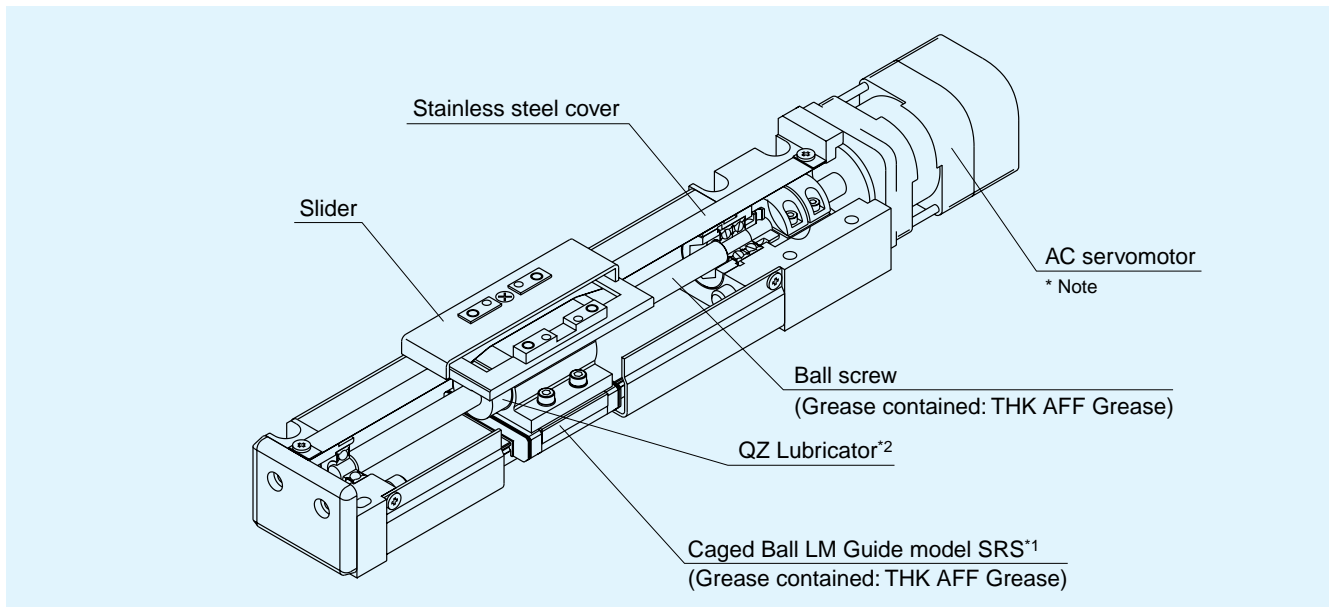

### Cylinder Type: Model VLA-CT

#### Structural drawing of Model VLA-CT

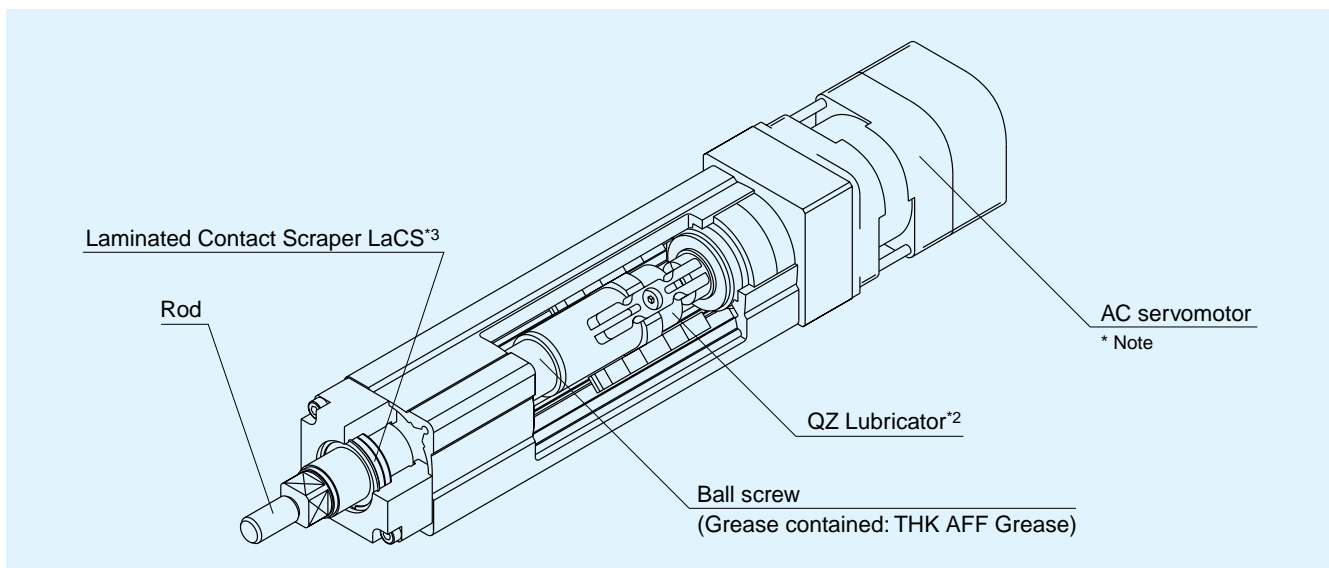

Note) Ac servomotors are not included in VLA actuator.  
Installation of the Motor need to be performed by customer.

# ator Model VLA

## ● Features of Model VLA

### ● Low Price with Simple Structure

Since model VLA uses an LM Guide as the direct base of the actuator unit and has fewer components, a simple structure, Lightweight and compact design are achieved. As a result, a low price actuator is realized.

### ● Long-term Maintenance-free Operation

Lightweight, compact type LM Guide model SRS<sup>\*1</sup>, which provides a significantly high performance through adoption of ball cages, is used in the linear motion guide unit. In addition, the ball screw unit is attached with QZ Lubricator<sup>\*2</sup>, which is capable of minimum and optimal lubrication. As a result, long-term maintenance-free operation is achieved.

### ● Eco-friendly and Highly Energy-efficient

By replacing a conventional air cylinder with Motored Actuator model VLA, the customer can eliminate exhaust noise and achieve high energy-efficiency and energy saving without contaminating the environment with lubrication oil mist.

### ● Productivity

Several manufacturers of motors can be assembled without additional flange according to your control specifications.

### ● A Motor of a Different Manufacturer Mountable

You can choose an AC servomotor to mount on the actuator from several manufacturers according to your control specifications.

Note: Mountable motors may be limited depending on the dimensions and the capacity. See page 14 for details.

### \*1: Caged Ball LM Guide model SRS

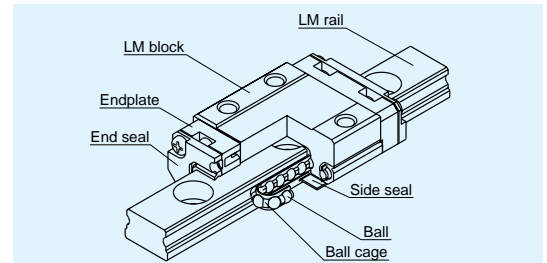

With model SRS, use of ball cages eliminates friction between balls and allows the following effects to be obtained.

- 1) Low noise, acceptable running sound
- 2) Long-term maintenance-free operation
- 3) High-speed response, long service life
- 4) Excellent smoothness
- 5) Low dust generation

### \*2: QZ Lubricator

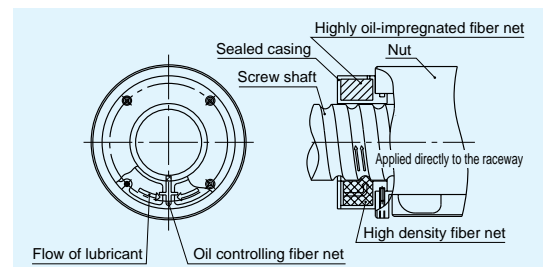

- 1) Substantially extended maintenance interval

With ordinary grease lubrication for a ball screw, slight amount of oil is lost as the ball screw travels. Attaching QZ Lubricator supplements oil loss over a long period and allows the maintenance intervals to be significantly extended.

- 2) Eco-friendly lubrication system

QZ Lubricator feeds the right amount of oil to the right location with a high density fiber net, making itself an eco-friendly lubrication system that does not waste oil.

### \*3: Laminated Contact Scraper LaCS

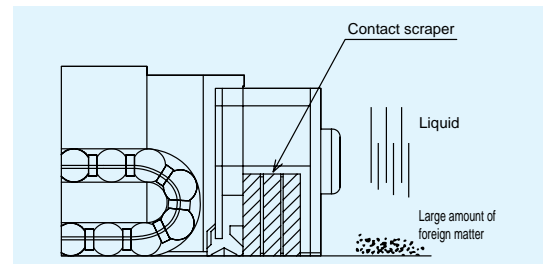

With a laminated contact structure (2-layer scraper), LaCS removes minute foreign matter adhering to the LM rail in multiple stages to prevent it from entering the LM block.

Low noise, acceptable running sound

- Since 2-layer scrapers are in full contact with the LM rail, LaCS is highly capable of removing minute foreign matter.
- Use of oil-impregnated expanded synthetic rubber with a self-lubricating capability achieves a low frictional resistance.

# Model VLA-ST

## ● Example of the actuator's model number coding

**VLA** — **ST** — **45** — **06** — **0150** — **N** — **000** — **N** — **N** — **N**

①      ②      ③      ④      ⑤      ⑥      ⑦      ⑧      ⑨      ⑩

- |  |   |   |
|--|---|---|
| ① Model number   | ⑤ Stroke<br>Ex. 0050: 50 mm<br>0200: 200 mm | ⑧ Motor encoder specifications<br>N: no motor |
| ② Type: ST   | ⑥ Type (mounting method)<br>N: no motor     | ⑨ Motor lead line direction<br>N: no motor    |
| ③ Classification in main unit size<br>45: 45-mm height<br>60: 60-mm height | ⑦ Motor wattage<br>000: no motor            | ⑩ Option<br>N: no option                      |
| ④ Ball screw lead<br>06: 6 mm<br>12: 12 mm                                 |   |   |

## ● Model VLA-ST Specifications

Model No.	Unit	ST-45 (30W)		ST-60 (50W)		ST-60 (100W)		
		High speed type	Medium speed type	High speed type	Medium speed type	High speed type	Medium speed type	
Rated speed <sup>(Note 1)</sup>	mm/s	600	300	600	300	600	300	
Maximum speed	mm/s	Stroke: 300 or less	1000	500	1000	500	1000	500
		Stroke: 350	1000	500	800	400	800	400
		Stroke: 400	1000	500	800	400	800	400
		Stroke: 450	840	420	800	400	800	400
		Stroke: 500	680	340	800	400	800	400
		Stroke: 550	\		800	400	800	400
		Stroke: 600			680	340	680	340
		Stroke: 700			500	250	500	250
Rated thrust	N	40	80	67	133	134	267	
Maximum thrust	N	117	235	201	402	398	796	
Maximum acceleration	G	0.3						
Horizontal mass capacity	kg	5	10	8	16	16	30	
Vertical mass capacity	kg	1.5	3	2.5	5	5	10	
Ball screw shaft diameter	mm	8		12				
Ball screw lead	mm	12	6	12	6	12	6	
Motor wattage <sup>(Note 3)</sup>	W	30		50		100		
Motor rated torque <sup>(Note 3)</sup>	N-m	0.095		0.159		0.319		
Positioning repeatability	mm	±0.02						
Backlash	mm	0.1						
Permissible moment	N-m	Ma=Mb=12 Mc=31		Ma=Mb=25.7 Mc=58				
Service life in distance traveled <sup>(Note 2)</sup>	km	5000						

Note 1: Both the rated speed and the maximum speed in the case of the 700mm stroke are 500mm/s for the high-speed type and 250mm/s for the medium-speed type.

Note 2: The value applies when the actuator receives a load and operates at the rated speed and acceleration of 0.3G

Note 3: The specifications apply to the actuator mounted with each size of a standard motor in page 14. If a different motor is used, the actuator's specifications are different. Also note that the rated values of the actuator unit must not be exceeded.

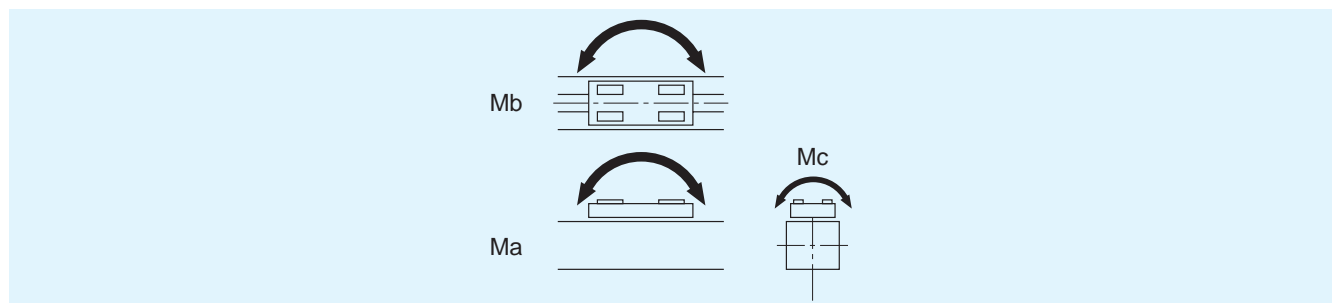



# ● Outline Drawing of Model VLA-ST-60

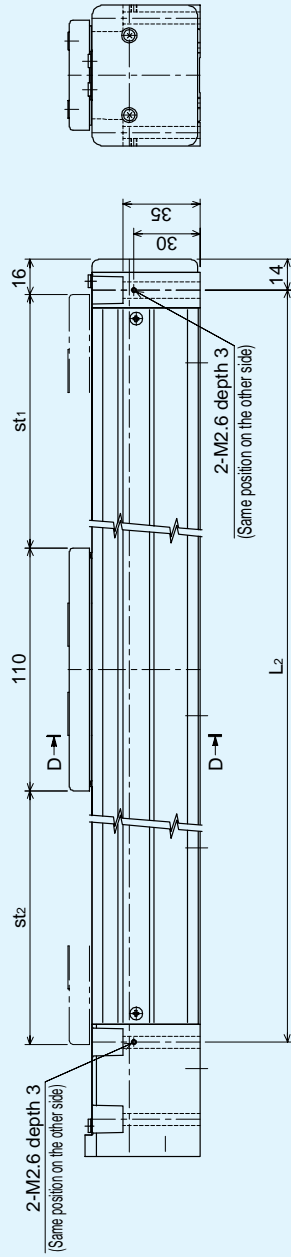
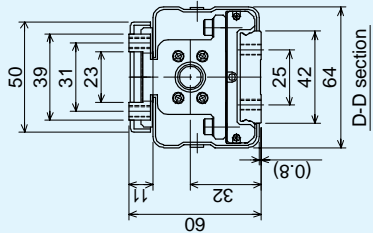
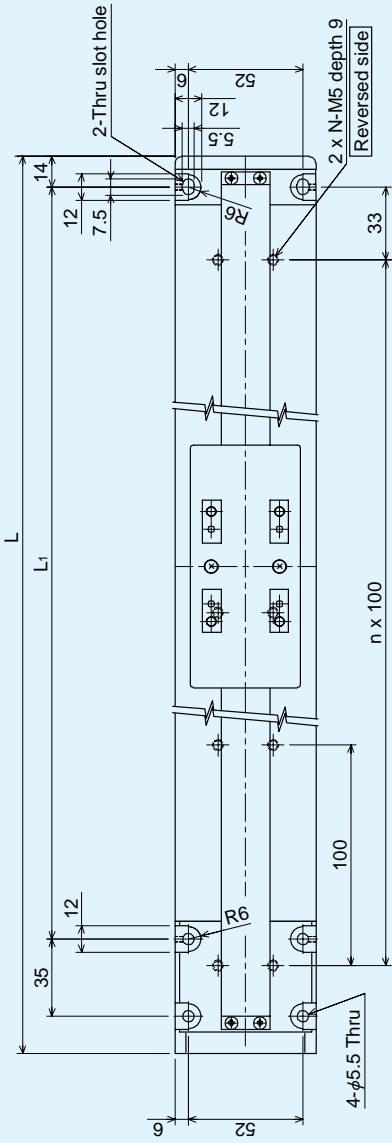
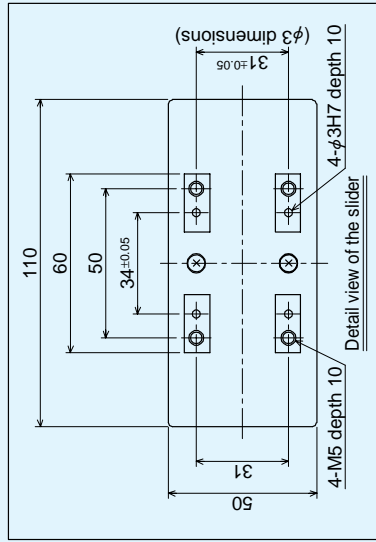

## ● Dimensions of the motor mounting section

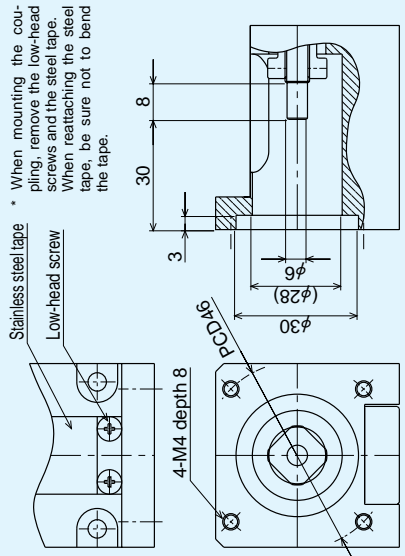

\* When mounting the coupling, remove the low-head screws and the steel tape. When reattaching the steel tape, be sure not to bend the tape.

Unit : mm

## Dimensional Table

Stroke	Effective stroke	Mechanical stroke st1+st2	L	L1	L2	n	N	Mass : kg
0050	50	60	237	171	171	1	2	1.9
0100	100	110	287	221	221	2	3	2.1
0150	150	160	337	271	271	2	3	2.3
0200	200	210	387	321	321	3	4	2.5
0250	250	260	437	371	371	3	4	2.7
0300	300	310	487	421	421	4	5	2.9
0350	350	360	537	471	471	4	5	3.1
0400	400	410	587	521	521	5	6	3.3
0450	450	460	637	571	571	5	6	4.0
0500	500	510	687	621	621	6	7	4.2
0550	550	560	737	671	671	6	7	3.5
0600	600	610	787	721	721	7	8	3.7
0700	700	710	887	821	821	8	9	4.6

## Model Number Coding of the Sensor Rail

**TH — VSR — 45 — 0100**

①                      ②                      ③                      ④

- ① Model number                      ④ Type  
 ② Class                                      Ex. 0100: for stroke 100mm  
     0250: for stroke 250mm  
 ③ Type  
     45: for VLA-ST-45  
     60: for VLA-ST-60

### TH-VSR-45

		Nominal stroke									
		0050	0100	0150	0200	0250	0300	0350	0400	0450	0500
L <sub>1</sub>	mm	141.6	191.6	241.6	291.6	341.6	391.6	441.6	491.6	541.6	591.6
L <sub>0</sub>		153.6	203.6	253.6	303.6	353.6	403.6	453.6	503.6	553.6	603.6

\* Screw for securing the sensor rail: number 0 pan-head screw (M2.6 x 4L)

### TH-VSR-60

		Nominal stroke												
		0050	0100	0150	0200	0250	0300	0350	0400	0450	0500	0550	0600	0700
L <sub>1</sub>	mm	171	221	271	321	371	421	471	521	571	621	671	721	821
L <sub>0</sub>		183	233	283	333	383	433	483	533	583	633	683	733	833

\* Screw for securing the sensor rail: number 0 pan-head screw (M2.6 x 4L)

## Dimensional Drawing of the Sensor Rail

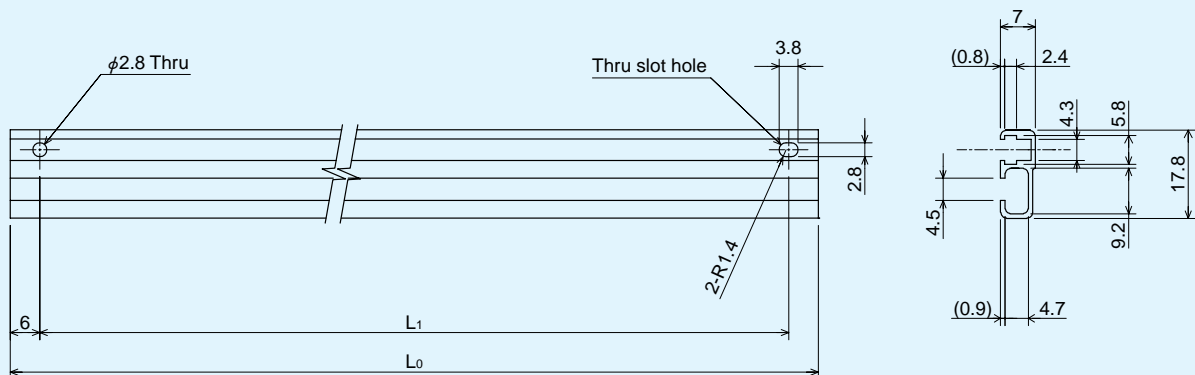

## Mountable Sensors

Manufacturer name	Photo sensor	Proximity sensor
OMRON	EE-SX674	
	EE-SX674P	
SUNX		GXL-N12F GXL-N12FB
Yamatake		APM-D3A1-001 APM-D3B1-003

\*1 The sensor dog cannot be mounted directly on the sensor unit. Mount it outside the sensor.

\*2 For sensors other than the above, contact THK.

## Example of Mounting Sensors

### Model ST-45

#### Proximity Sensors

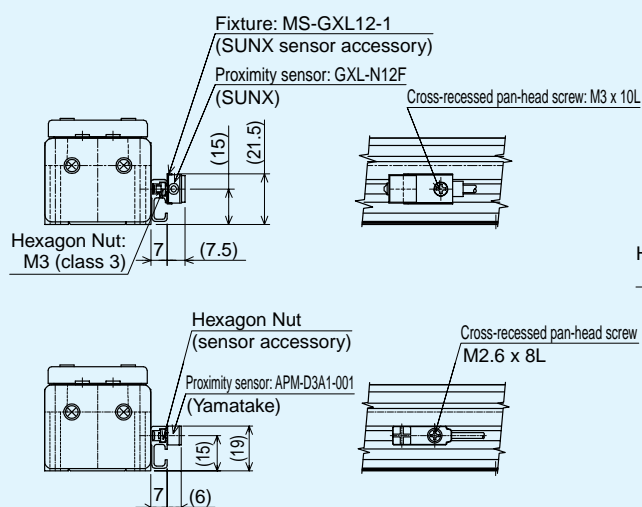

#### Photo Sensors

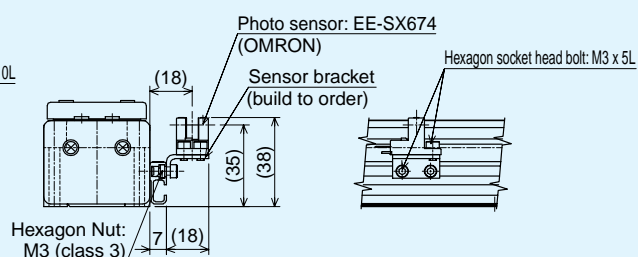

### Model ST-60

#### Proximity Sensors

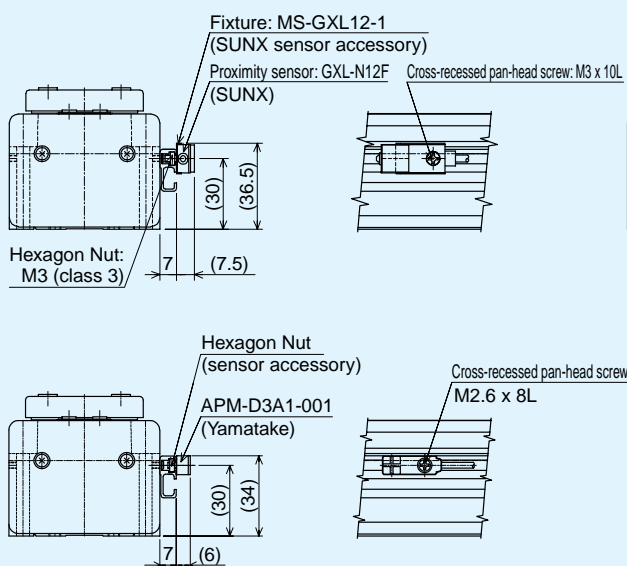

#### Photo Sensors

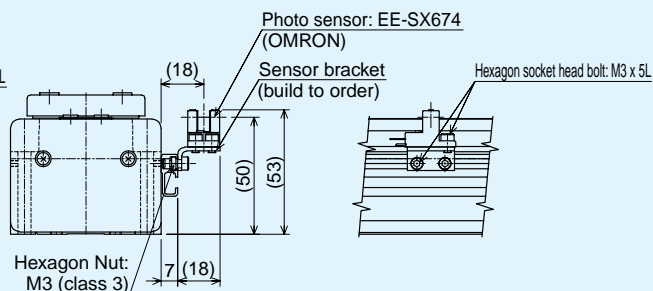

Note: The mounting bolts of the sensor must be prepared by the user.



# Model VLA-CT

## ● Example of the actuator's model number coding

VLA — CT — 35 — 12 — 0150 — N — 000 — N — N — N  
 ①            ②            ③            ④            ⑤            ⑥            ⑦            ⑧            ⑨            ⑩

① Model number	⑤ Stroke Ex. 0050: 50 mm 0200: 200 mm	⑧ Motor encoder specifications N: no motor
② Type: CT	⑥ Type (mounting method) N: no motor	⑨ Motor lead line direction N: no motor
③ Classification in main unit size 35: 35 mm width 45: 45 mm width 55: 55 mm width	⑦ Motor wattage 000: no motor	⑩ Option A: Bracket Base B: Flange N: no option
④ Ball screw lead 06: 6 mm 12: 12 mm		

## ● Model VLA-CT Specifications

Item	Unit	CT-35 (30W)		CT-45 (50W)		CT-55 (100W)	
		High speed type	Medium speed type	High speed type	Medium speed type	High speed type	Medium speed type
Rated speed <sup>(Note 1)</sup>	mm/s	600	300	600	300	600	300
Rated thrust	N	40	80	67	134	134	267
Maximum thrust	N	120	240	201	402	402	804
Horizontal mass capacity <sup>(Note 2, 3)</sup>	kg	4	8	7	14	25	40
Vertical mass capacity <sup>(Note 3)</sup>	kg	1.9	3.8	3.1	6.2	6.5	10.5
Ball screw lead	mm	12	6	12	6	12	6
Positioning repeatability	mm	±0.02					
Ball screw shaft diameter	mm	8				12	
Motor wattage <sup>(Note 5)</sup>	W	30		50		100	
Motor rated torque <sup>(Note 5)</sup>	N-m	0.095		0.158		0.318	
Rod diameter	mm	φ16		φ20		φ25	
Stroke	mm	50/100/150		50/100/150/200		50/100/150/200/250/300	
Service life in distance traveled <sup>(Note 4)</sup>	km	5000					

Note 1: The rated speed is 470mm/s for the high-speed type and 235mm/s for the medium-speed type of model CT55 with a 300mm stroke, according to the critical speed of the Ball Screw. With shorter strokes, model CT55 can operate at up to 500mm/s for the medium-speed type or up to 1,000mm/s for the high-speed type. However, the service life may be shortened.

Note 2: Model CT is capable of receiving only an axial load. The horizontal mass capacity is the value when an LM Guide is also used and no axial load is applied to the rod. When making a selection, take into account the sliding resistance of the LM Guide. For specific sliding resistances of LM Guides, see the general catalog.

Note 3: The values apply at acceleration of 0.3G.

Note 4: The specifications apply to the actuator mounted with each size of a standard motor in page 14. If a different motor is used, the actuator's specifications are different. Also note that the rated values of the actuator unit must not be exceeded.

Note 5: The value applies when the actuator receives a load and operates at the rated speed and acceleration of 0.3G.

## ● Outline Drawing of Model VLA-CT-35

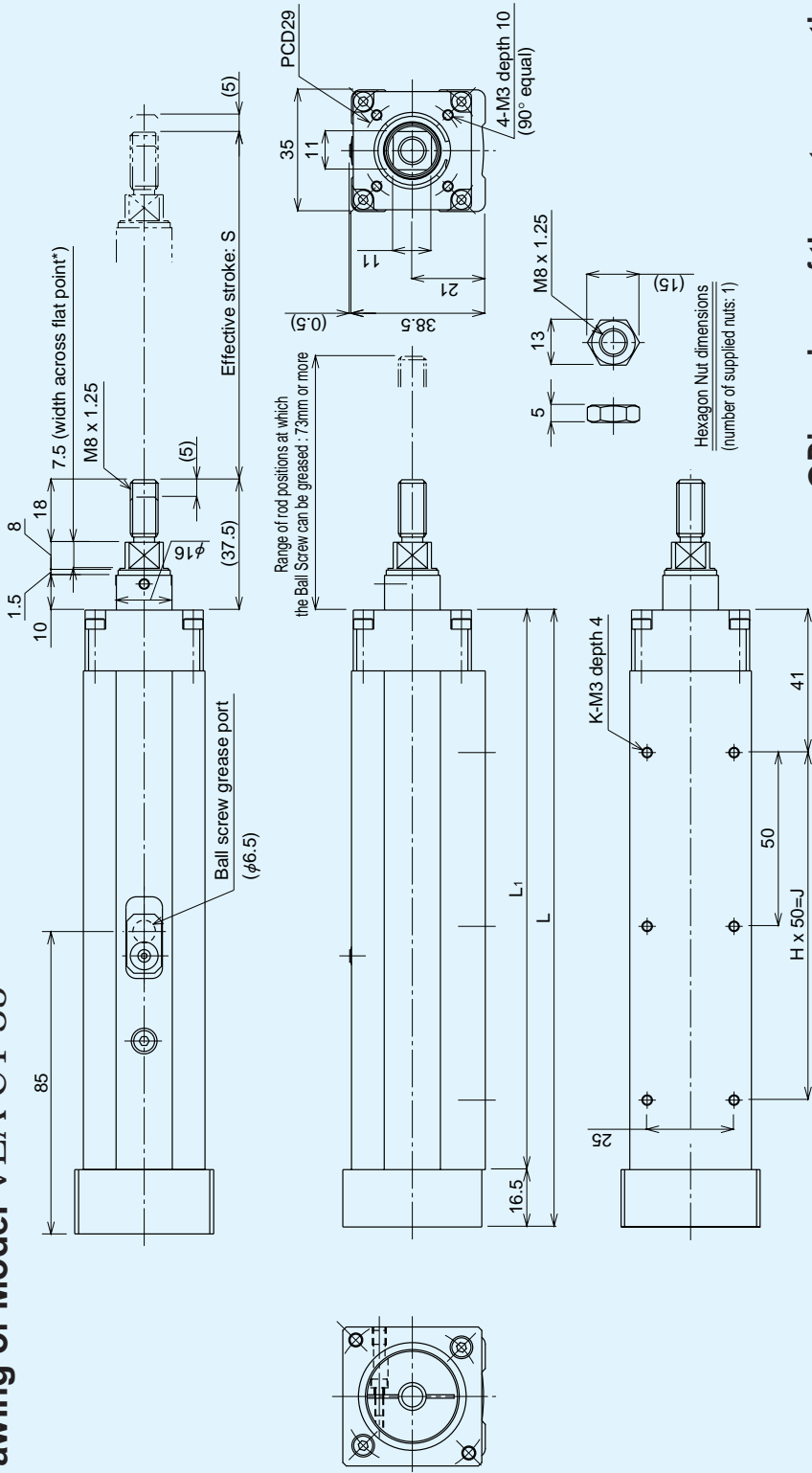

## ● Dimensions of the motor mounting section

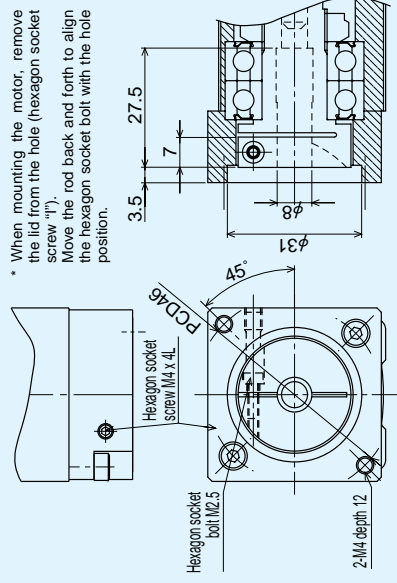

## Dimensional Table

Unit : mm

Stroke	Effective stroke: S	L	L <sub>1</sub>	H	J	K	Mass : kg
0050	50	177.5	161	2	100	6	0.7
0100	100	227.5	211	3	150	8	0.9
0150	150	277.5	261	4	200	10	1.0

\* The direction to the baseside is not fixed.





# ●Options for Model VLA-CT

## Bracket Base

[Option symbol]: A

### CT-35

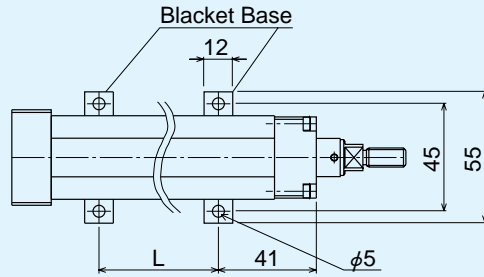

Unit : mm

Nominal Stroke	L
50	100
100	150
150	200

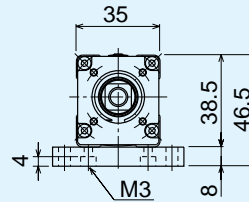
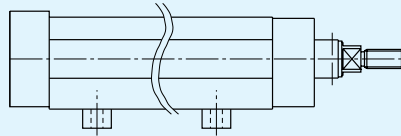

### CT-45<sup>\*1</sup>

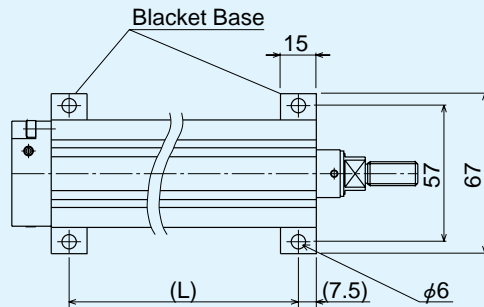

Unit : mm

Nominal Stroke	L
50	147.5
100	197.5
150	247.5
200	297.5

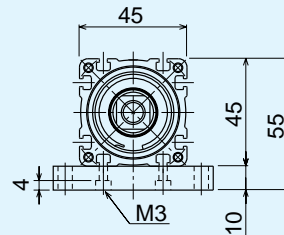
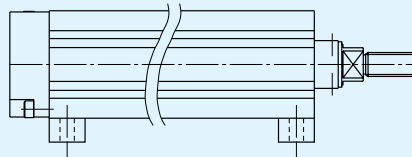

### CT-55<sup>\*1</sup>

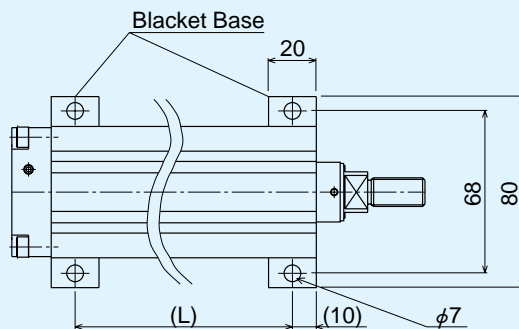

Unit : mm

Nominal Stroke	L
50	163
100	213
150	263
200	313
250	363
300	413

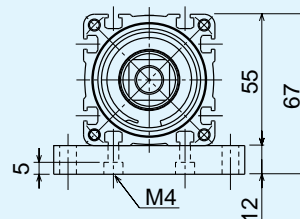
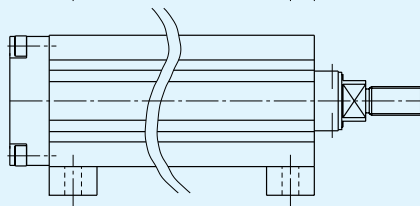

The bracket base is an option available in a 2-piece set.

\*1: CT-45 and CT-55 are each provided with two square nuts.

Flange

[Option symbol]: B

CT-35

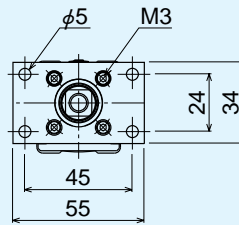
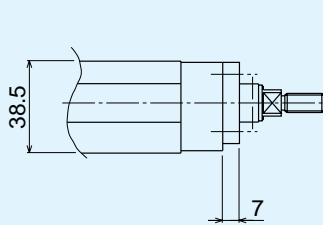
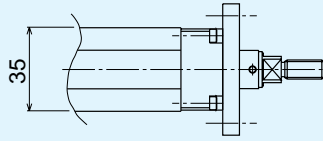

CT-45

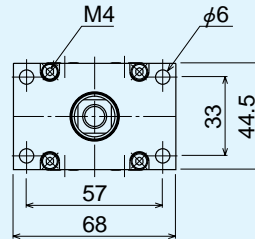
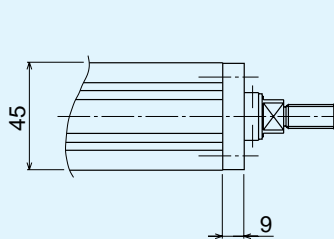
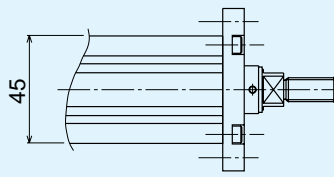

CT-55

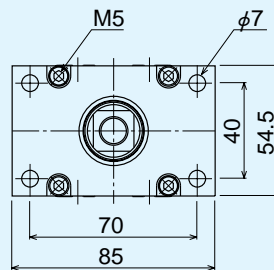
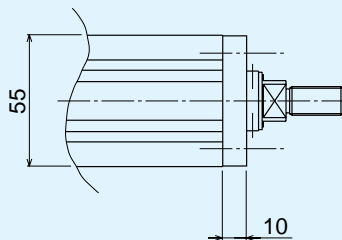
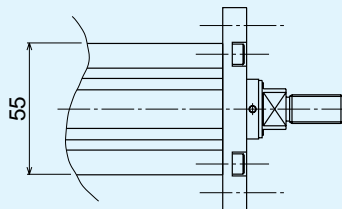

Note: Each flange is attached to the actuator in the position as indicated in the figure when the actuator is shipped.

## ● Specifications of Mountable Motors

With model VLA, any of the motors indicated in the table below can be mounted without an intermediate flange.

\* For details of the motor mounting area, see the corresponding drawing P.4~5, P.9~11.

\* For the specifications and options of a motor of a particular manufacturer, see the manufacturer's catalog and select and purchase one.

Model No.		Applicable Actuator		
		ST Type	CT Type	
FANUC	$\beta$ M0.2	ST-60		
	$\beta$ M0.3			
YASKAWA	$\Sigma$ -III	SGMAS-A5	CT-55	
		SGMAS-01		
	$\Sigma$ -II	SGMAH-A3	ST-45	
		SGMAH-A5	ST-60	
SGMAH-01	CT-55			
MITSUBISHI	J-3	HF-KP053	CT-45	
		HF-KP13	CT-55	
		HF-MP053	CT-45	
		HF-MP13	CT-55	
	J2-Super	HC-MFS053	ST-60	CT-45
		HC-MFS13		CT-55
		HC-KFS053		CT-45
		HC-KFS13		CT-55
	HC-PQ033		ST-45	CT-35
	HC-PQ053		ST-60	CT-45
	HC-PQ13			CT-55
OMRON	R7M-Z10030		CT-55	
	R88M-W03030		CT-55	
	R88M-W05030			
	R88M-W10030		ST-60	
SANYO DENKI	Q1AA04003		ST-45	
	Q1AA04005		CT-45	
	Q1AA04010			CT-55
KEYENCE	MV-M05		CT-45	
	MV-M10		CT-55	

\* For motor shaft, select a straight shaft.

\* Customer to provide options and accessories for custom motors, such as, brakes, encoders, cables etc. Refer to the motor manufacturer's catalog to select options.

\* If a custom motor is specified, actuator specification may change. The actuator is pre-set standard motor specifications. The actuator is not capable to operated beyond its rated preset conditions.

\* Controller adjustments to be made by customer.

\* With VLA-ST units with no motor mounted, no coupling attached. Customer to provide own coupling.

\* If you select a coupling for ST-45, be sure the coupling length must be 20mm or less. If the coupling length is longer than 20mm, the outer diameter must be 18.5mm or less.

# THK Low Price Actuator Model VLA

## Precautions on Use

### ●Service environment

Using the actuator and the controller in an adverse environment may cause failure. Be sure to use them in places such as the following.

- Indoor place with ambient temperature 0 to 40°C and ambient humidity 20 to 80% RH, and with no freezing or condensation
- Place with no corrosive gas or flammable gas
- Place with no inductive power such as iron power, dust, oil mist, cutting fluid, moisture, salt or organic solvent in the air
- Place with no direct sunlight or radiant heat
- Place with no intense electric field or intense magnetic field
- Place where vibrations or impact will not transmit to the unit
- Place where the unit can easily be inspected and cleaned

### ●Mounting surface for the actuator

- The mounting surface must be machined flat or similarly accurate planar, with flatness within 0.050/200mm for VLA-ST-45, 0.060/200mm for VLA-ST-60, or 0.1mm for VLA-CT.

### ●Precautions on safety

- Do not drop or hit the product. Doing so may cause injury or failure.
- Do not disassemble the product. Doing so may cause foreign material to enter the product or deteriorate its accuracy. Disassembling the controller may cause electric shock.
- Never touch the moving part of the actuator while it is energized. Do not enter the operating range of the actuator while it is operating or operable.
- Before installing, adjusting, inspecting or maintaining the actuator unit, the controller or the equipment to which the actuator or controller is connected, be sure to disconnect every power plug from the outlet, and lock the outlet or apply a safety plug in order to prevent people other than the operator from turning on the power again. In addition, post a "work in progress" notice in a place where it is easily visible.
- If two or more people are involved in operating the product, familiarize them with the procedures, signs and anomaly handling in advance, and appoint another person for overseeing their operation.
- Carefully read and fully understand the instruction manual, and be sure to observe the safety precautions.

### ■Instruction manual

- You can download the "Instruction Manual for Low-Priced Actuator Model VLA" and the "Instruction Manual for the Personal Computer Communication Software" from THK's website. THK website: <http://www.thk.com/>

### ■CAD data, personal computer communication software

- You can download the CAD data of the actuator and the personal computer communication software (including English indications) from THK Technical Support site. Technical Support site: <https://tech.thk.com/>

●"LM GUIDE" and " are the registered trademarks of THK CO., LTD.

●The photo may differ slightly in appearance from the actual product.

●The appearance and specifications of the product are subject to change without notice. Contact THK before placing an order.

●Although great care has been taken in the production of this catalog, THK will not take any responsibility for damage resulting from typographical errors or omissions.

●For the export of our products or technologies and for the sale for exports, THK in principle complies with the foreign exchange law and the Foreign Exchange and Foreign Trade Control Law as well as other relevant laws.

For export of THK products as single items, contact THK in advance.

All rights reserved.

# THK CO., LTD.

HEAD OFFICE 3-11-6, NISHI-GOTANDA, SHINAGAWA-KU, TOKYO 141-8503 JAPAN  
INTERNATIONAL SALES DEPARTMENT PHONE:+81-3-5434-0351 FAX:+81-3-5434-0353  
Global site : <http://www.thk.com/>

### NORTH AMERICA

THK America, Inc.

#### ●HEADQUARTERS

Phone:+1-847-310-1111 Fax:+1-847-310-1271

#### ●CHICAGO OFFICE

Phone:+1-847-310-1111 Fax:+1-847-310-1182

#### ●NORTH EAST OFFICE

Phone:+1-845-369-4035 Fax:+1-845-369-4909

#### ●ATLANTA OFFICE

Phone:+1-770-840-7990 Fax:+1-770-840-7897

#### ●LOS ANGELES OFFICE

Phone:+1-949-955-3145 Fax:+1-949-955-3149

#### ●SAN FRANCISCO OFFICE

Phone:+1-925-455-8948 Fax:+1-925-455-8965

#### ●DETROIT OFFICE

Phone:+1-248-858-9330 Fax:+1-248-858-9455

#### ●TORONTO OFFICE

Phone:+1-905-820-7800 Fax:+1-905-820-7811

### SOUTH AMERICA

THK Brasil LTDA

Phone:+55-11-3767-0100 Fax:+55-11-3767-0101

### EUROPE

THK GmbH

#### ●EUROPEAN HEADQUARTERS

Phone:+49-2102-7425-555 Fax:+49-2102-7425-556

#### ●DÜSSELDORF OFFICE

Phone:+49-2102-7425-0 Fax:+49-2102-7425-299

#### ●FRANKFURT OFFICE

Phone:+49-2102-7425-650 Fax:+49-2102-7425-699

#### ●STUTTGART OFFICE

Phone:+49-7150-9199-0 Fax:+49-7150-9199-888

#### ●MÜNCHEN OFFICE

Phone:+49-8937-0616-0 Fax:+49-8937-0616-26

#### ●U.K. OFFICE

Phone:+44-1908-30-3050 Fax:+44-1908-30-3070

#### ●ITALY MILANO OFFICE

Phone:+39-039-284-2079 Fax:+39-039-284-2527

#### ●ITALY BOLOGNA OFFICE

Phone:+39-051-641-2211 Fax:+39-051-641-2230

#### ●SWEDEN OFFICE

Phone:+46-8-445-7630 Fax:+46-8-445-7639

#### ●AUSTRIA OFFICE

Phone:+43-7229-51400 Fax:+43-7229-51400-79

#### ●SPAIN OFFICE

Phone:+34-93-652-5740 Fax:+34-93-652-5746

#### ●TURKEY OFFICE

Phone:+90-216-362-4050 Fax:+90-216-569-7150

#### ●PRAGUE OFFICE

Phone:+420-2-41025-100 Fax:+420-2-41025-199

#### ●MOSCOW OFFICE

Phone:+7-495-649-80-47 Fax:+7-495-649-80-44

#### THK Europe B.V.

#### ●EINDHOVEN OFFICE

Phone:+31-040-290-9500 Fax:+31-040-290-9599

#### THK France S.A.S.

Phone:+33-4-3749-1400 Fax:+33-4-3749-1401

### CHINA

THK (CHINA) CO., LTD.

#### ●HEADQUARTERS

Phone:+86-411-8733-7111 Fax:+86-411-8733-7000

#### ●SHANGHAI OFFICE

Phone:+86-21-6219-3000 Fax:+86-21-6219-9890

#### ●BEIJING OFFICE

Phone:+86-10-8441-7277 Fax:+86-10-6590-3557

#### ●CHENGDU OFFICE

Phone:+86-28-8526-8025 Fax:+86-28-8525-6357

#### ●GUANGZHOU OFFICE

Phone:+86-20-8523-8418 Fax:+86-20-3801-0456

THK (SHANGHAI) CO., LTD.

Phone:+86-21-6275-5280 Fax:+86-21-6219-9890

### TAIWAN

THK TAIWAN CO., LTD.

#### ●TAIPEI HEAD OFFICE

Phone:+886-2-2888-3818 Fax:+886-2-2888-3819

#### ●TAICHUNG OFFICE

Phone:+886-4-2359-1505 Fax:+886-4-2359-1506

#### ●TAINAN OFFICE

Phone:+886-6-289-7668 Fax:+886-6-289-7669

### KOREA

SEOUL REPRESENTATIVE OFFICE

Phone:+82-2-3468-4351 Fax:+82-2-3468-4353

### SINGAPORE

THK LM SYSTEM Pte. Ltd.

Phone:+65-6884-5500 Fax:+65-6884-5550

### INDIA

BANGALORE REPRESENTATIVE OFFICE

Phone:+91-80-2330-1524 Fax:+91-80-2314-8226

