

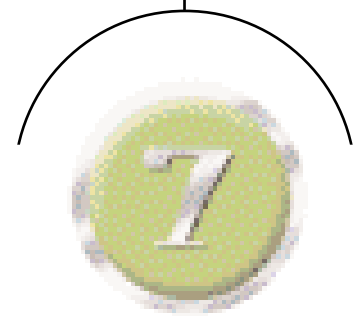

es  
me  
es  
es  
es

## CATENE PER APPLICAZIONI SPECIALI





## CATENE PER APPLICAZIONI SPECIALI - INDUSTRIA AGROALIMENTARE

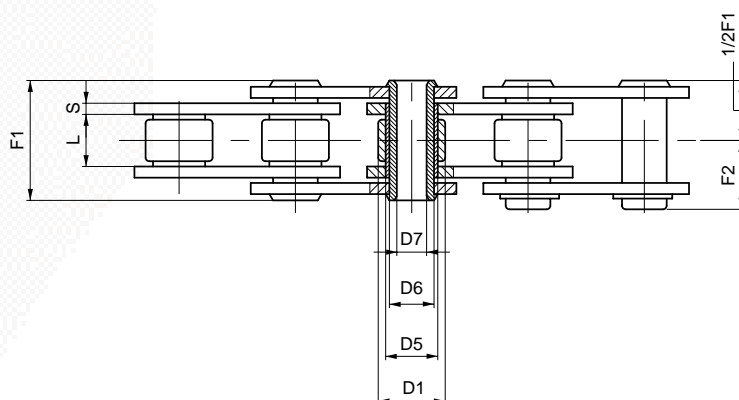
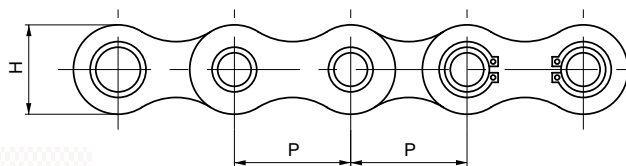

Combinazione montaggio attacchi da pag. 1.9./2

### A PERNI FORATI

Catena N.	P mm	L mm	D1 mm	D5 mm	D6 mm	D7 mm	H mm	S mm	F1 mm	F2 mm	Carico di rottura N	Peso cat. kg/m
❖ 3520Z	35	16	20	17	14	10,4	26	2,5	31	16,7	25.000	2,2
3520R	35	16	20	17	14	10,4	26	2,5	31	16,7	40.000	2,2
❖ 4020Z	40	16	20	17	14	10,4	30	2,5	31	16,7	25.000	2,3

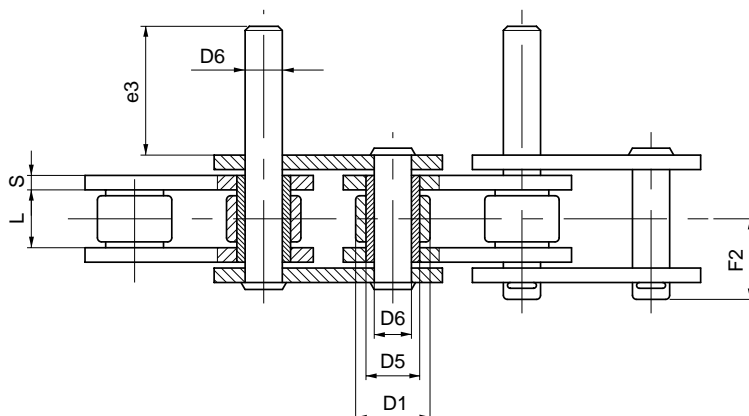
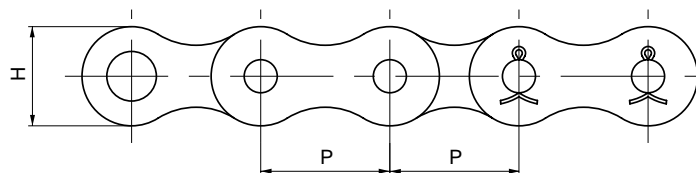

### A PERNI SPORGENTI

Catena N.	P mm	L mm	D1 mm	D5 mm	D6 mm	H mm	S mm	F2 mm	F6 mm	e3 mm	Carico di rottura N	Peso cat. kg/m
❖ 3521Z	35	16	20	13	10	26	2,5	50,5	67,5	35	35.000	2,8
▲ W3033...	38,1	13	12	8,5	10	18	3	17,5	80,0	35	38.000	2,2
▲ W3109...	38,1	13	22,5	8,5	10	18	3	17,5	80,0	35	38.000	2,3

❖ esecuzione zincata

▲ esecuzione zincata o nichelata



CATENE PER APPLICAZIONI SPECIALI - INDUSTRIA AUTOMOBILISTICA

IMPIANTO  
PENDOLO

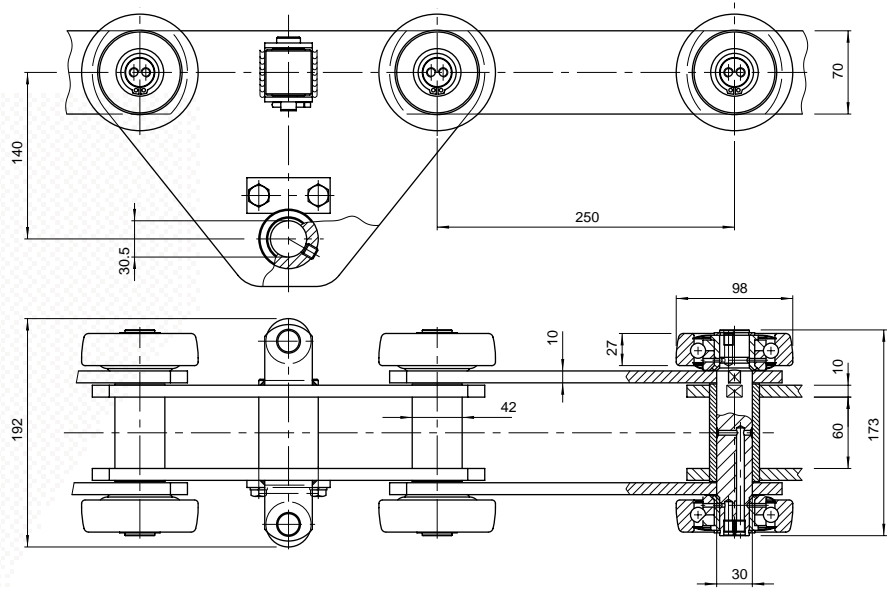

Catena P. 250x60x42  $\varnothing$ B



Carico di rottura: 370.000 N

IMPIANTO  
PENDOLO

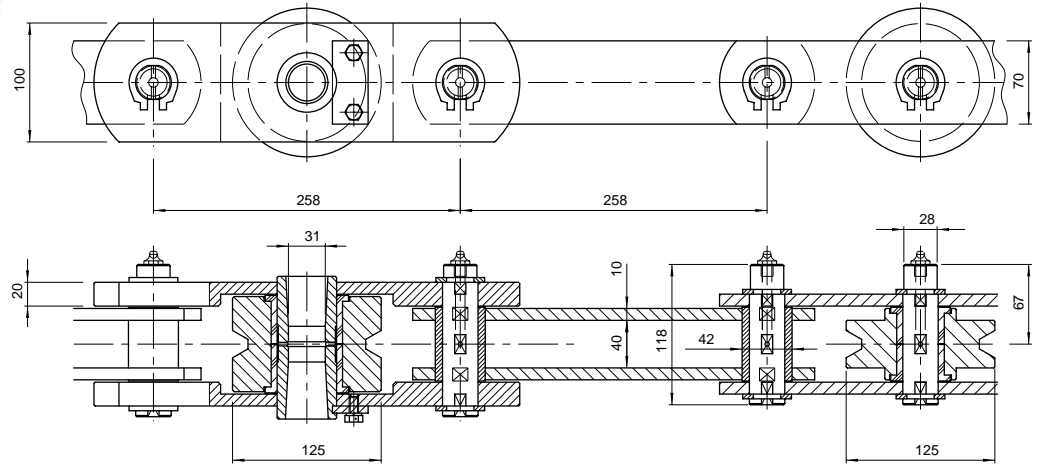

Catena P. 258x40x42  $\varnothing$ B



Carico di rottura: 405.000 N

CATENE PER APPLICAZIONI SPECIALI - INDUSTRIA AUTOMOBILISTICA

IMPIANTO  
PENDOLO

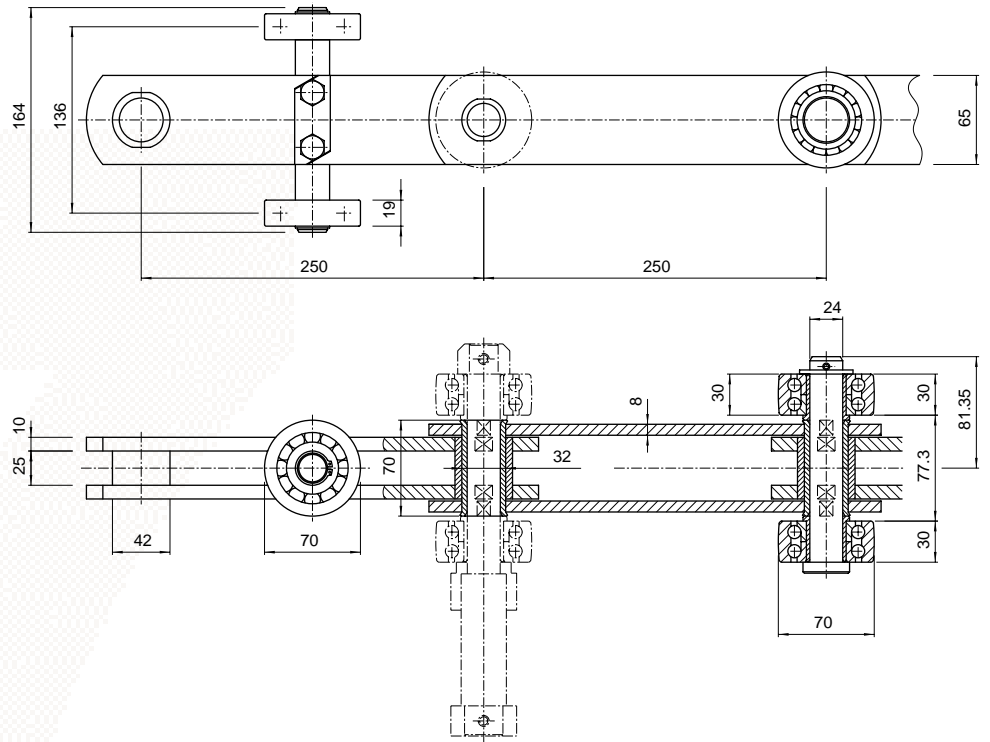

Catena P. 250x25x42 øB



Carico di rottura: 380.000 N

IMPIANTO  
PENDOLO

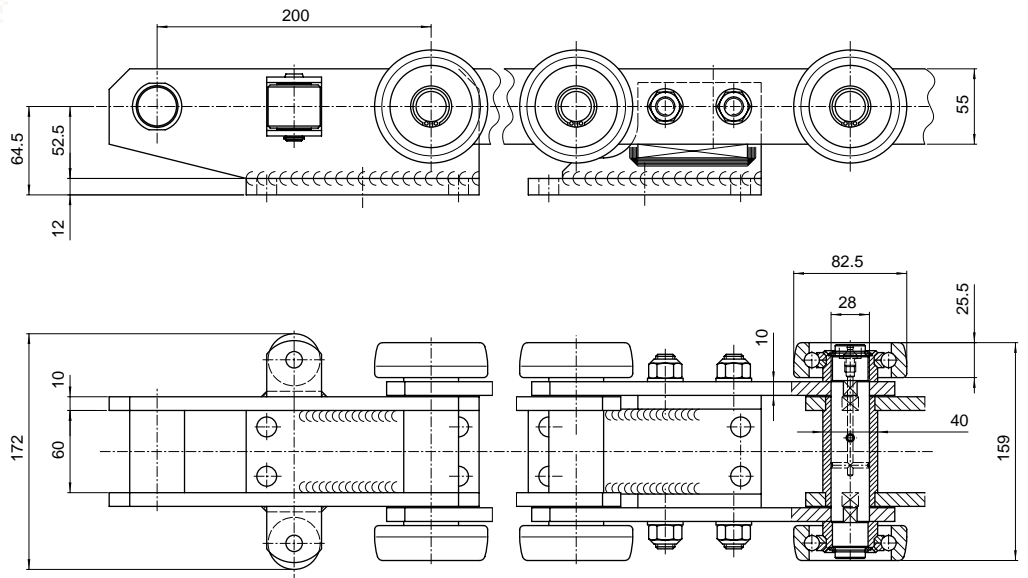

Catena P. 200x60x40 øB



Carico di rottura: 300.000 N



# CATENE PER APPLICAZIONI SPECIALI - INDUSTRIA AUTOMOBILISTICA

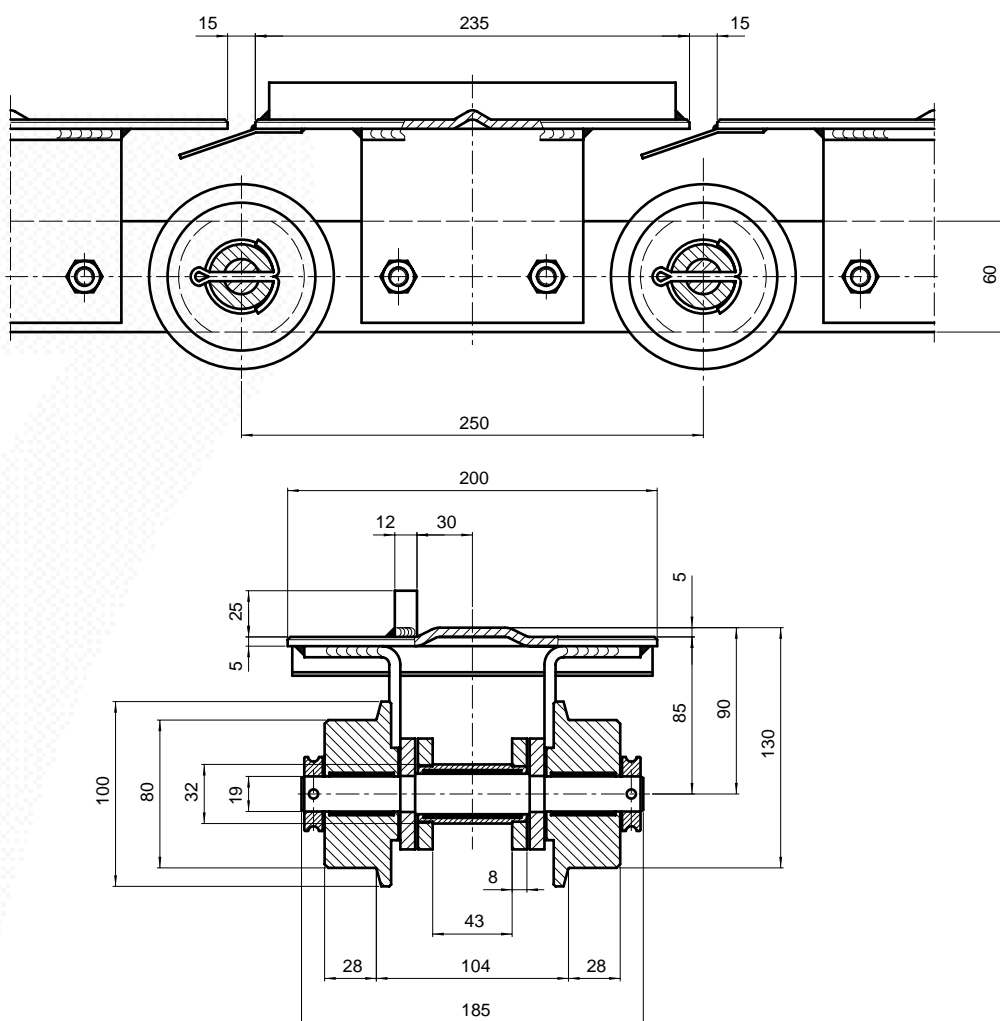

FORNI  
DI ESSICAZIONE

Catena P. 250x43x32 øB



Carico di rottura: 224.000 N

Esente da lubrificazione e manutenzione

CATENE PER APPLICAZIONI SPECIALI - INDUSTRIA AUTOMOBILISTICA

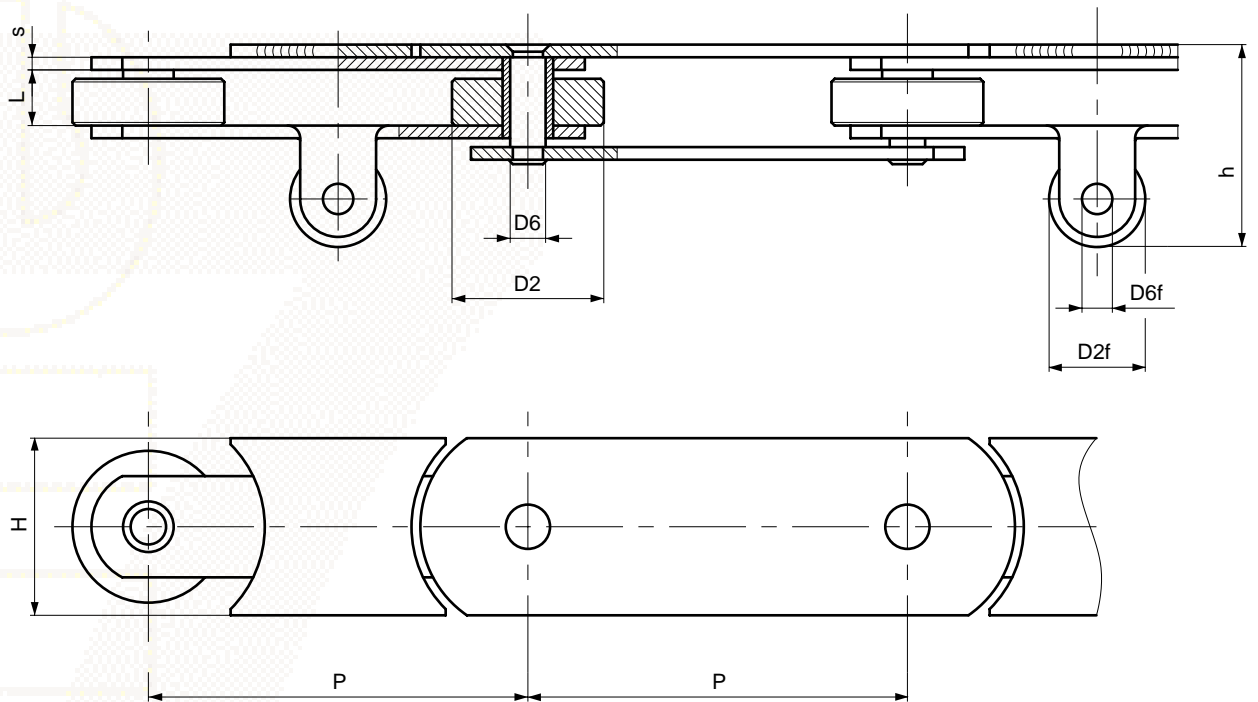

MOVIMENTAZIONE  
SKIDS

Catena N.	P mm	L mm	D2 mm	D6 mm	H mm	S mm	D2f mm	D6f mm	h mm	Carico di rottura N
W4697	100	22	60	14	70	5	38	12	81	160.000
W2527R	150	22	60	14	70	5	38	12	81	160.000
W2542R	150	22	60	22	80	8	70	18	131	220.000
W4028R	150	22	60	14	100	5	38	12	81	160.000
W2595R	150	22	60	14	80	5	38	12	81	160.000

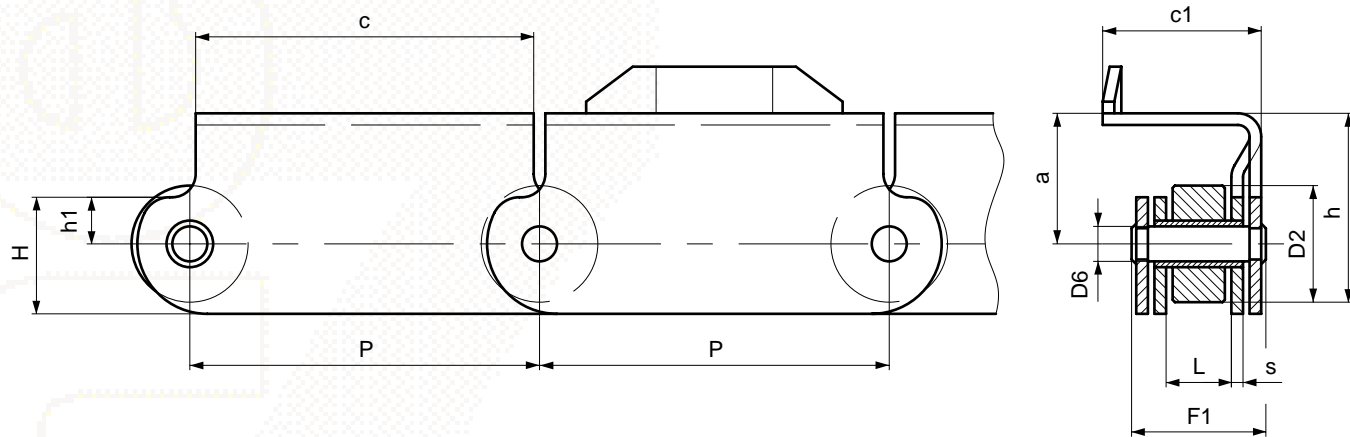

MOVIMENTAZIONE  
SKIDS

Catena N.	P mm	L mm	D2 mm	D6 mm	H mm	h mm	h1 mm	S mm	F1 mm	a mm	c mm	c1 mm	Carico di rottura N
W2359	150	28	50	15	50	81	20	5	55	56	145	68	160.000
W3057	150	28	50	15	50	85	20	5	55	60	145	65	160.000
W3349	150	32	50	14	55	81	20	5	58,5	56	145	80	160.000
W2387	150	32	50	14	55	81	20	6	63	56	145	80	160.000



CATENE PER APPLICAZIONI SPECIALI - INDUSTRIA AUTOMOBILISTICA

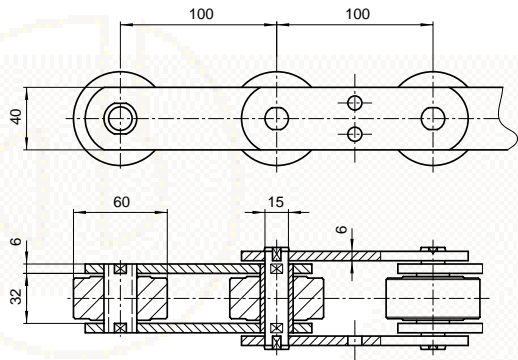

MOVIMENTAZIONE  
SKIDS

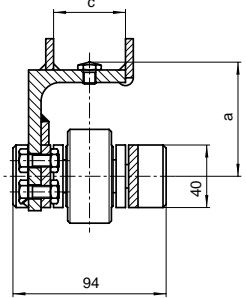
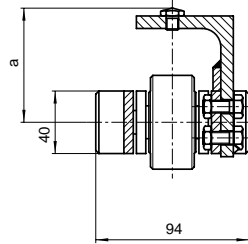
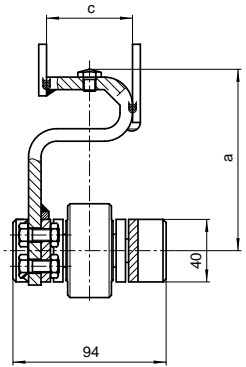
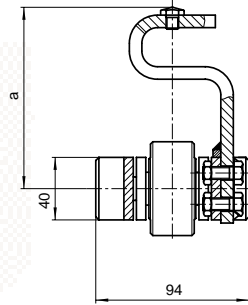

Catena P. 100x32x60 øR



Carico di rottura: 112.000 N

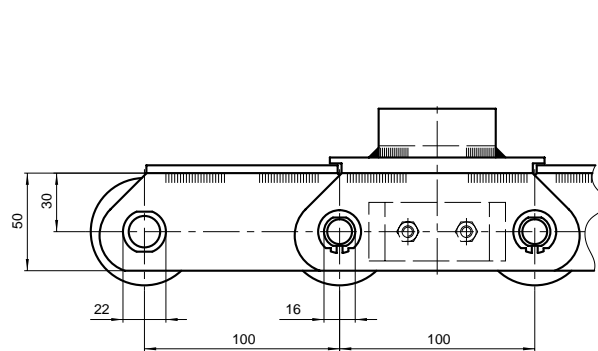

MOVIMENTAZIONE  
SKIDS

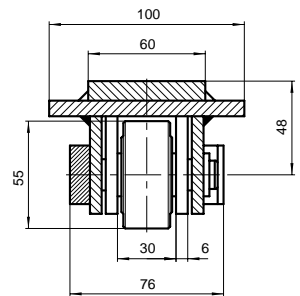
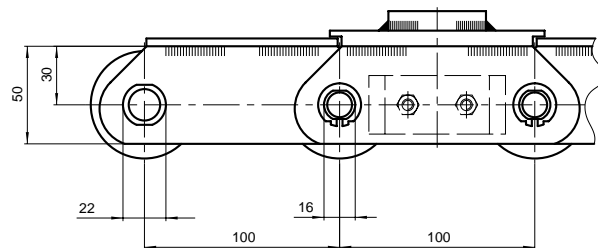
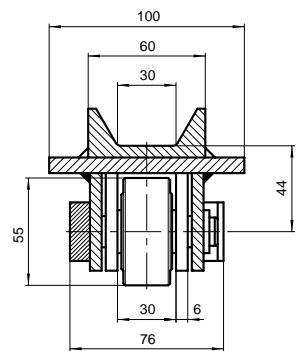

Catena P. 100x30x55 øR



Carico di rottura: 120.000 N



CATENE PER APPLICAZIONI SPECIALI - INDUSTRIA AUTOMOBILISTICA

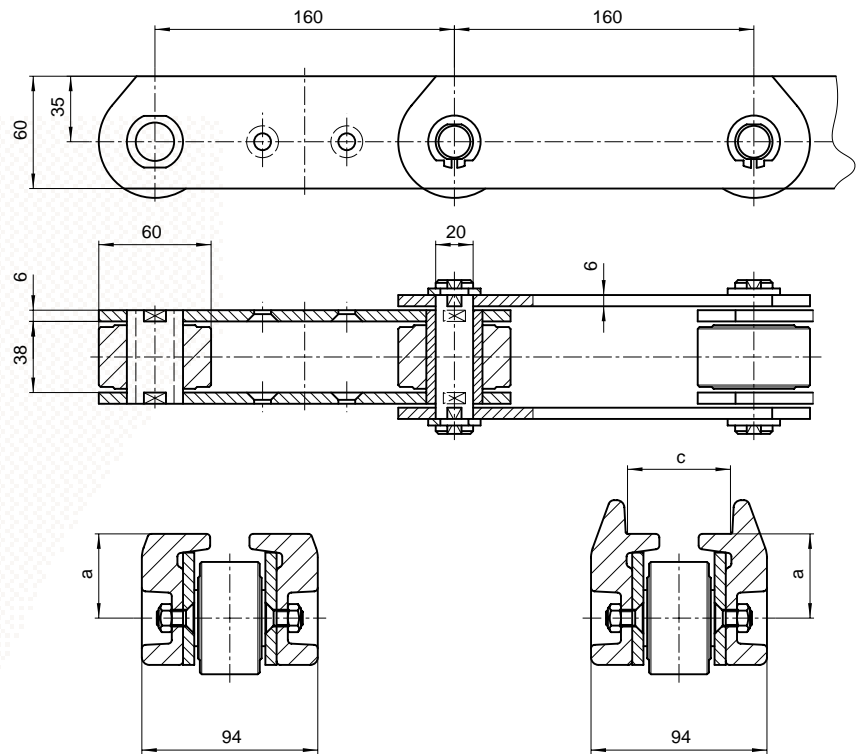

MOVIMENTAZIONE  
SKIDS

Catena P. 160x38x60 øR

 Carico di rottura: 200.000 N

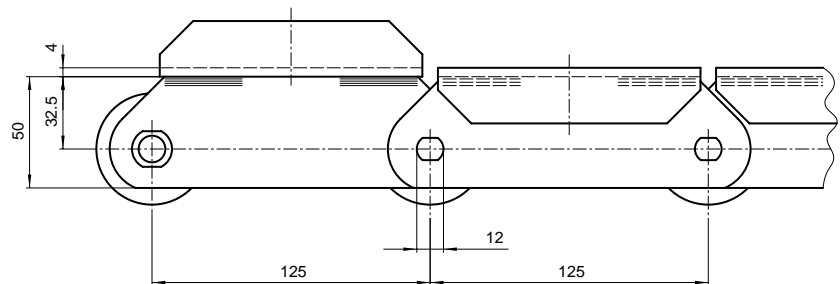

MOVIMENTAZIONE  
SKIDS

Catena P. 125x28x50 øR

 Carico di rottura: 80.000 N



CATENE PER APPLICAZIONI SPECIALI - INDUSTRIA AUTOMOBILISTICA

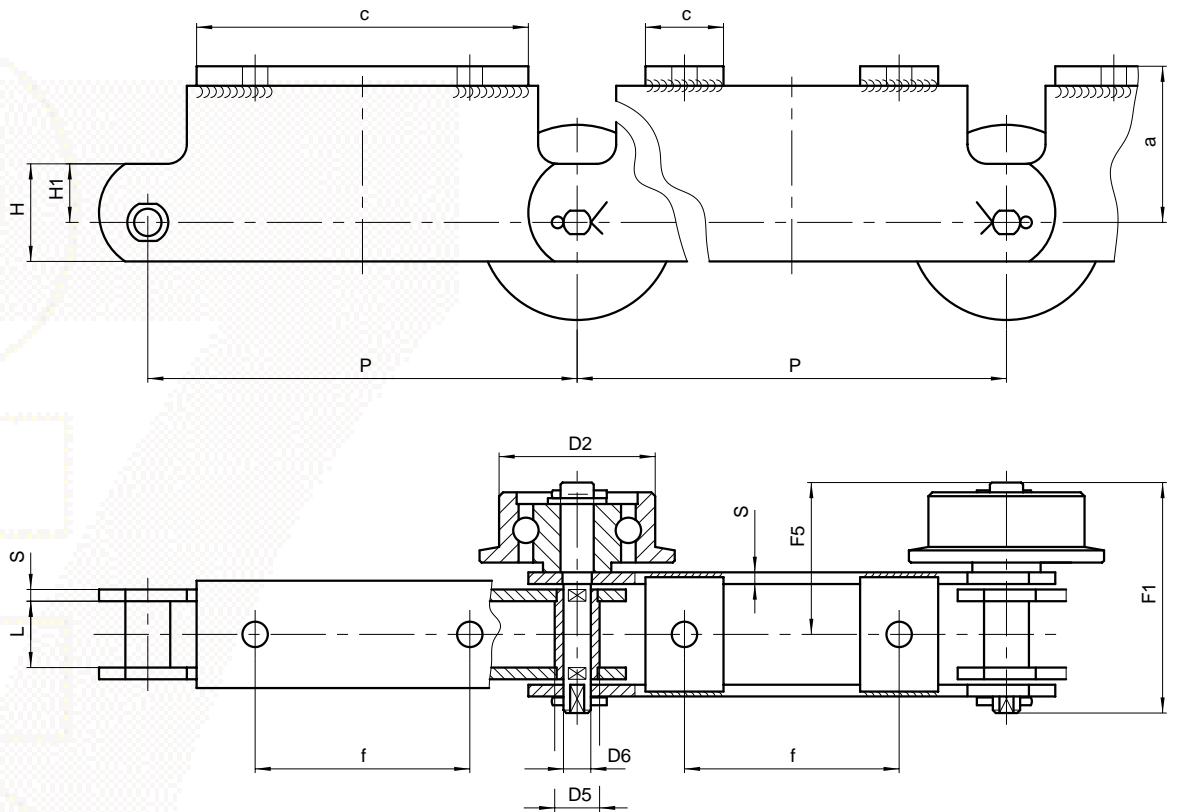

MOVIMENTAZIONE  
VETTURE

Catena N.	P mm	L mm	D2 mm	D5 mm	D6 mm	H mm	H1 mm	S mm	F1 mm	F5 mm	a mm	c mm	f mm	Carico di rottura N
W3810	220	34	80	23	14	50	31	6	114,5	76	80	170	110	140.000
W4031L	220	34	80	30	20	90	60	6	115	76	72	40	154	224.000
W4986LR	220	34	80	30	20	60	25	6	130,5	91,5	65	50	170	224.000
W4779	250	32	80	21	15	60	40	6	110,5	73,5	48	50	140	112.000
W4952	250	32	100	34	25	100	60	6	122,5	81,5	70	50	130	240.000
W4999	250	34	/	30	20	80	48	6	116	77	58	50	185	260.000
W5022	250	34	80	30	20	90	60	6	115	76	72	40	184	170.000

# CATENE PER APPLICAZIONI SPECIALI - INDUSTRIA AUTOMOBILISTICA

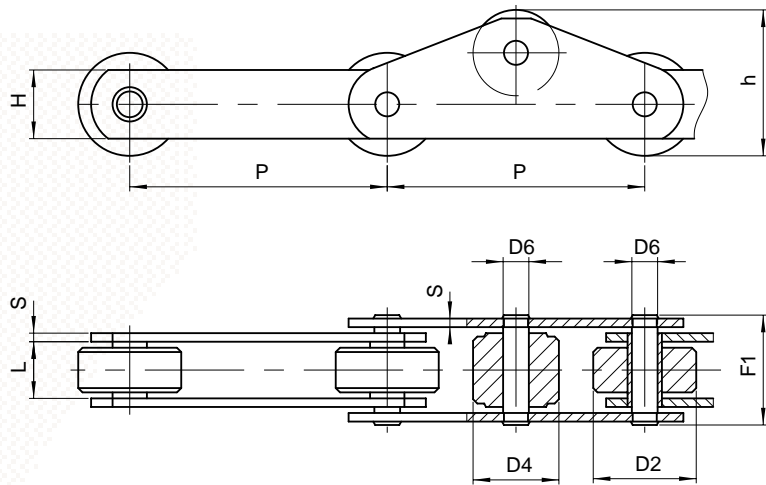

## MOVIMENTAZIONE SKIDS

Catena N.	P mm	L mm	D2 mm	D4 mm	D6 mm	H mm	S mm	F1 mm	h mm	Carico di rottura N	Note
W2165	50	25	20	24	10	25	4	45	32	56.000	RP su maglie est.
W2165A	50	25	20	24	10	/	4	45	32	56.000	RP su tutti i passi
W3836A	125	28	25	42	12	35	5	54,5	53,5	80.000	RP su maglie est.
W1669	150	28	60	50	15	40	5	54,5	85	160.000	RP su maglie est.
W5165	200	50	60	60	18	50	7	85	65	160.000	RP su tutti i passi

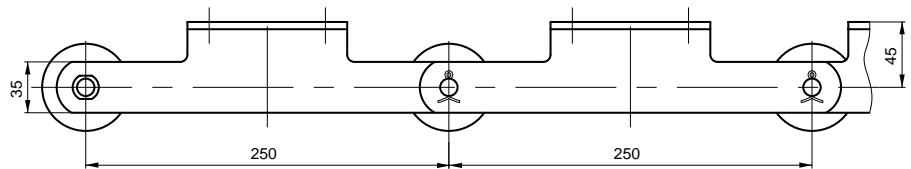

## PROVA IDRICA

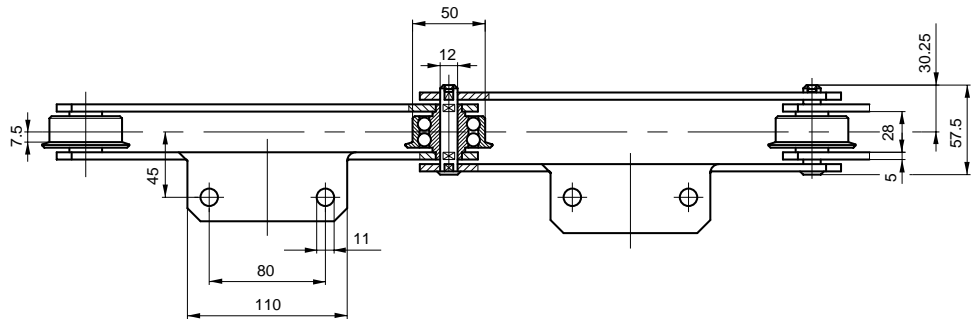

Catena P. 250x28x50/60 øR | Materiali di costruzione: Acc. INOX | Rullo cuscinetto con tenute stagne | Carico di rottura: 80.000 N

CATENE PER APPLICAZIONI SPECIALI - INDUSTRIA AUTOMOBILISTICA

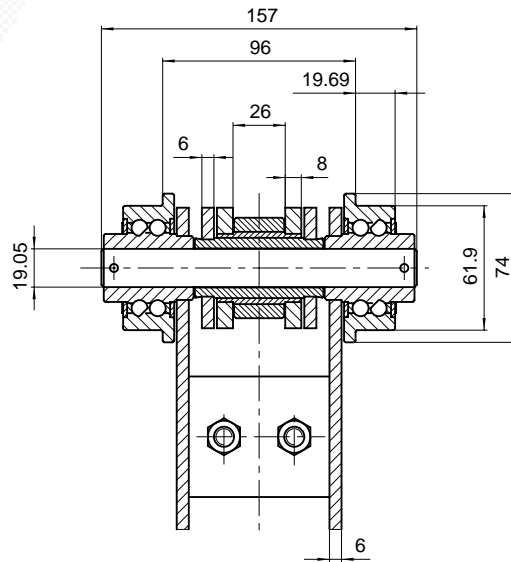
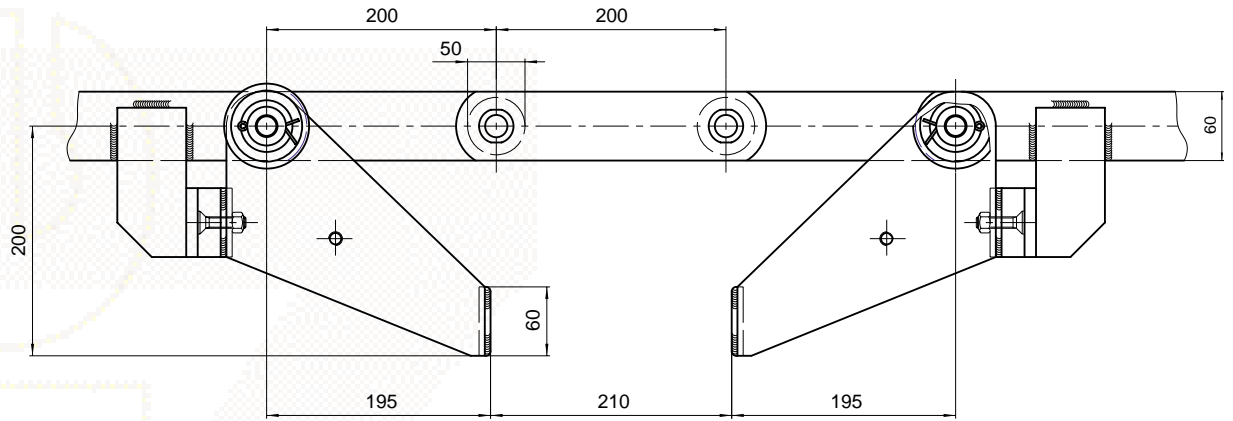

ACCOMPAGNATORI  
ASCENSORI  
DISCENSORI

Catena P. 200x26x60 øR



Carico di rottura: 300.000 N



CATENE PER APPLICAZIONI SPECIALI - INDUSTRIA AUTOMOBILISTICA

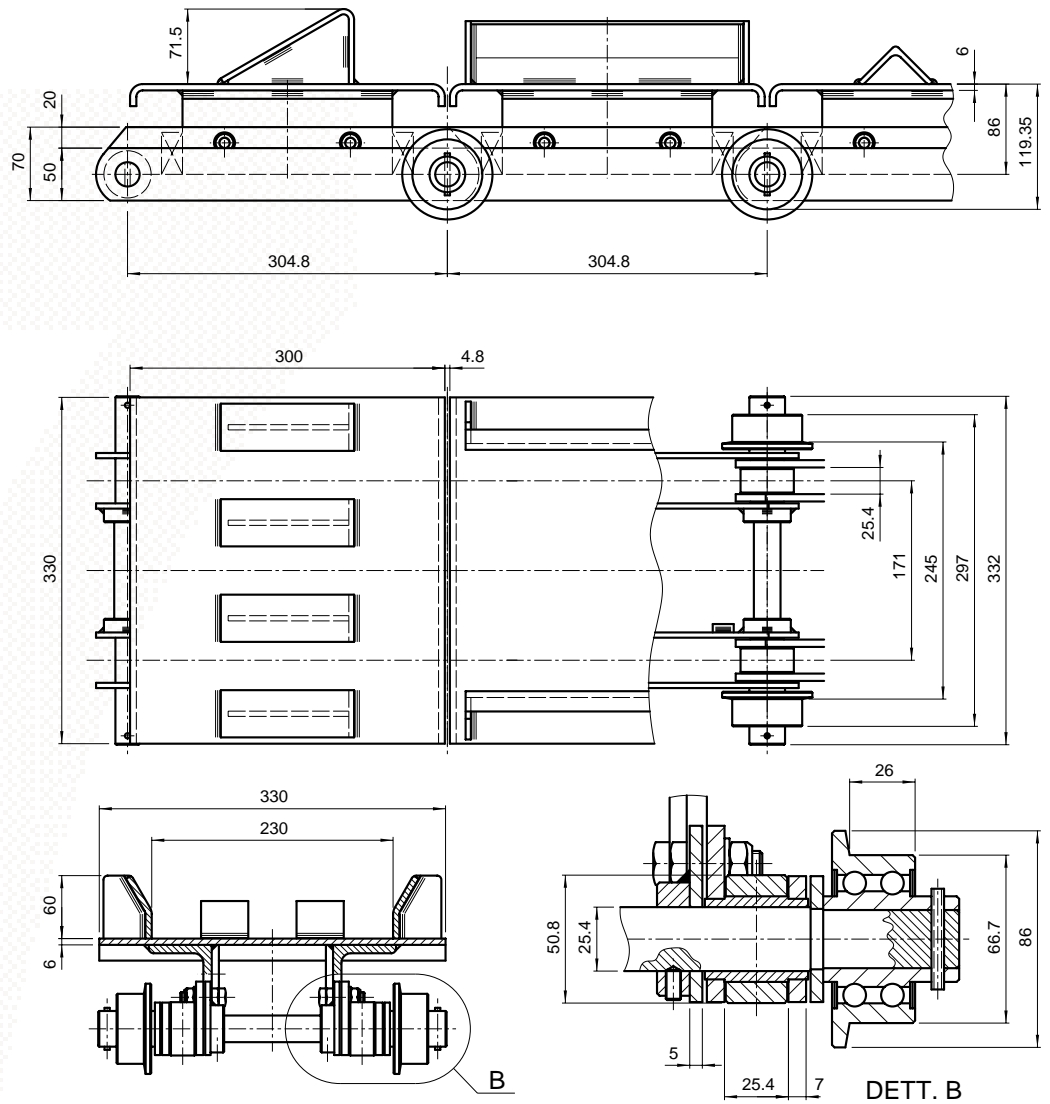

PROVA IDRICA

Catena P. 304,8x25,4x50,8 øR

Materiali di costruzioni:  
Acciai trattati e zincati



Carico di rottura: 300.000 N

# CATENE PER APPLICAZIONI SPECIALI - INDUSTRIA CALZATURIERA

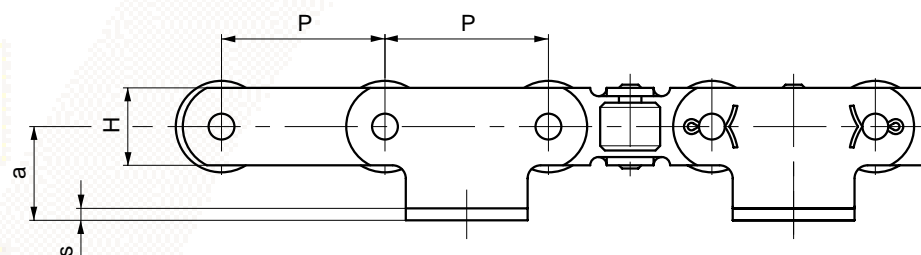
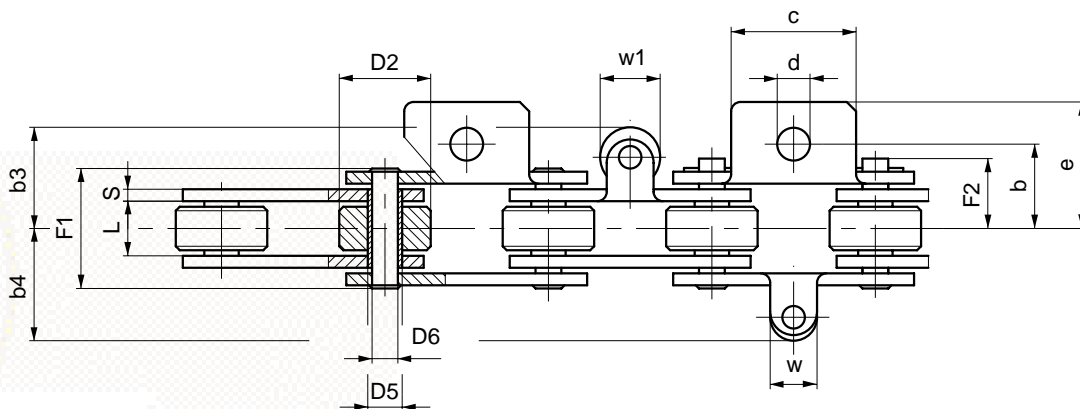

## MANOVIE

Catena N.	P mm	L mm	D2 mm	D5 mm	D6 mm	H mm	S/s mm	F1 mm	F2 mm	 Carico di rottura N	Peso cat. kg/m
10337	50	11,5	25	8,4	5,7	15	2	23,8	14,6	16.000	1,4
10381	50	11,5	25	8,4	5,7	15	2	23,8	14,6	16.000	1,4
103391	50	11,5	25	8,4	5,7	15	2	23,8	14,6	16.000	1,5
103476	50	11,5	25	8,4	5,7	15	2	23,8	14,6	16.000	1,4
W1364A	50	11,5	25	8,4	5,7	14	2,5	24,9	15,7	18.000	1,7
W2518	50	11,5	25	8,4	5,7	15	2	23,8	14,6	16.000	1,4

## ATTACCHI

Catena N.	P mm	a mm	b mm	c mm	d mm	e mm	w mm	w1 mm	b3 mm	b4 mm	Note
10337	50	25	21	41	6,5	32	12	/	/	24	
10381	50	24	/	24,5	/	31,2	12	/	/	24	
103391	50	25	21	41	6,5	32	12	14	22,5	24	
103476	50	25	21	41	6,5	32	/	14	22,5	/	
W1364A	50	/	/	41,5	6,5	23,3	/	14	28,8	/	Attacco verticale
W2518	50	24,5	/	40	/	57,5	/	14	22,5	/	



CATENE PER APPLICAZIONI SPECIALI - INDUSTRIA DELLA CARTA

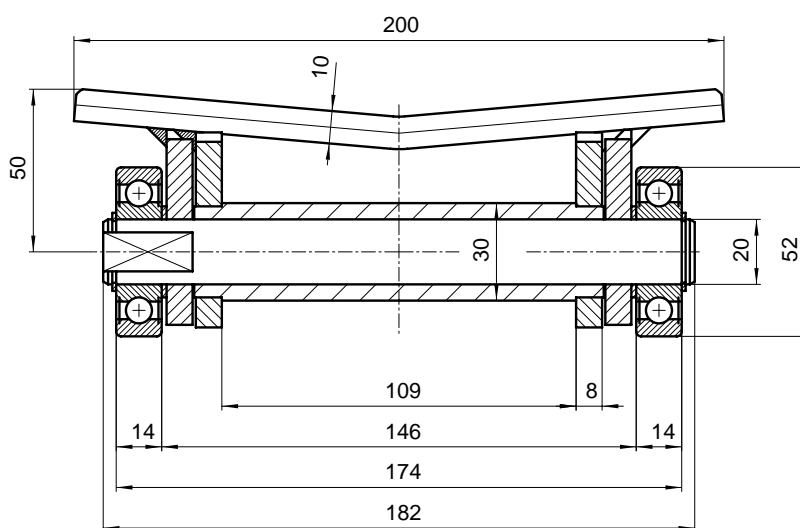
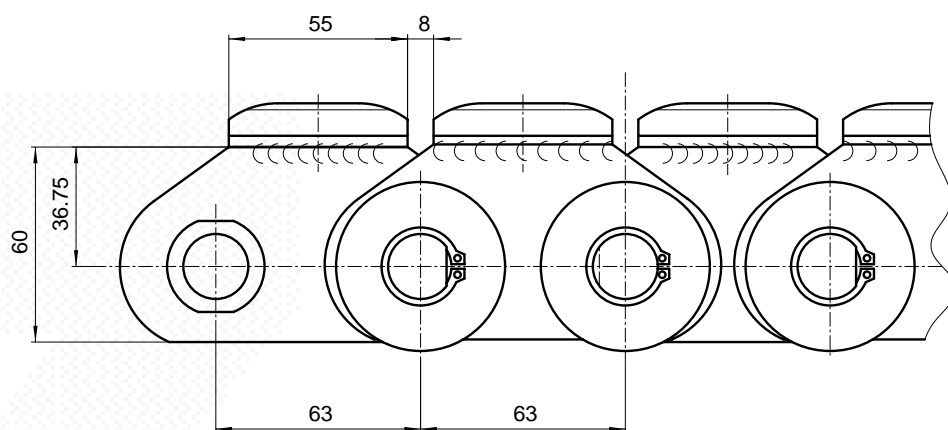

MOVIMENTAZIONE  
BOBINE

Catena P. 63x109x30 øB



Carico di rottura: 210.000 N

Ruote cuscinetto esterne, ambo i lati



# CATENE PER APPLICAZIONI SPECIALI - INDUSTRIA DELLA CARTA

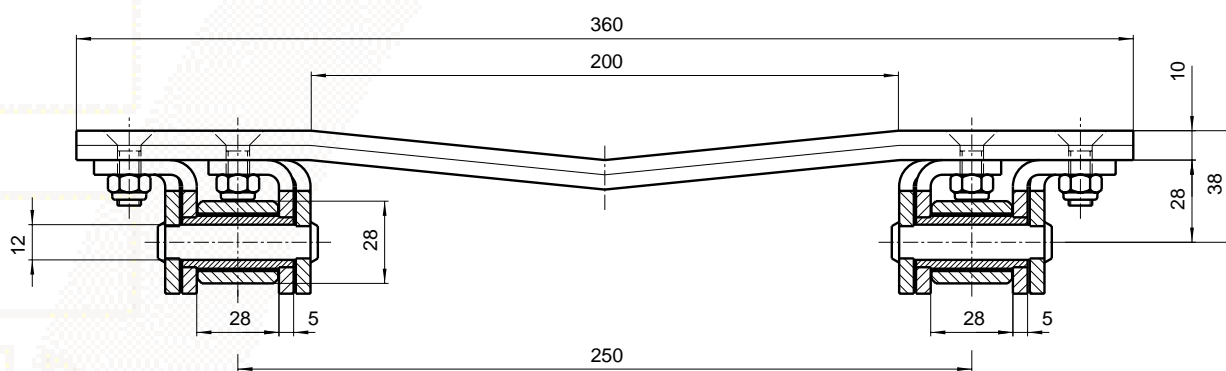
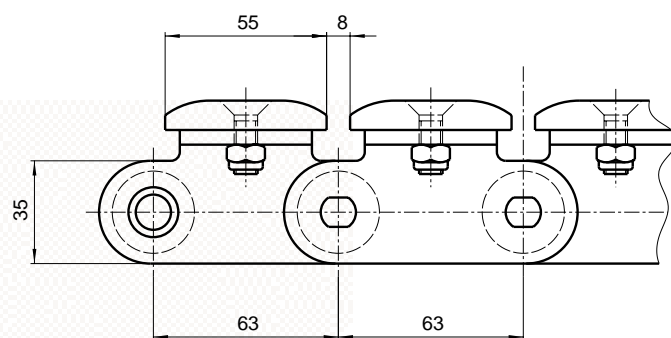

MOVIMENTAZIONE  
BOBINE

Catena P. 63x28x28 øR



Carico di rottura: 80.000 N (cad. catena)



CATENE PER APPLICAZIONI SPECIALI - INDUSTRIA DELLA CARTA

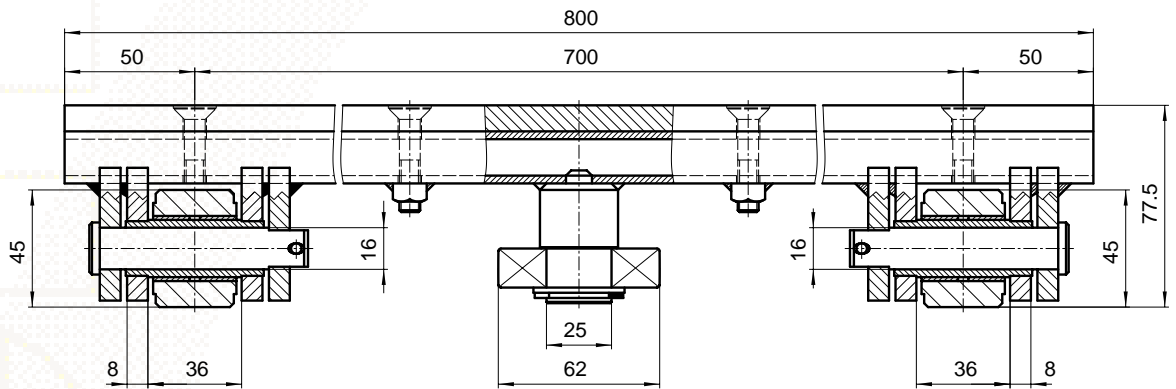
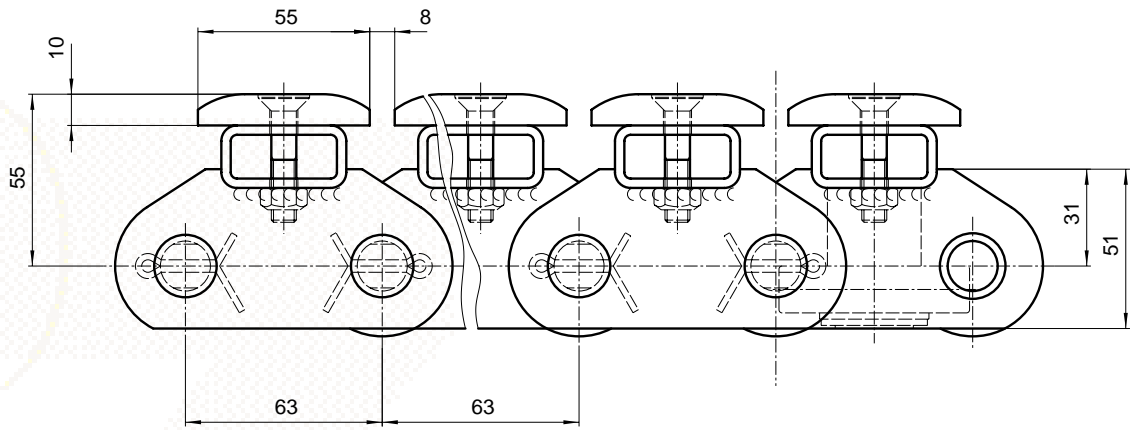

MOVIMENTAZIONE  
BOBINE

Catena P. 63x36x45 øR



Carico di rottura: 120.000 N (cad. catena)

# CATENE PER APPLICAZIONI SPECIALI - CELLE DI LIEVITAZIONE

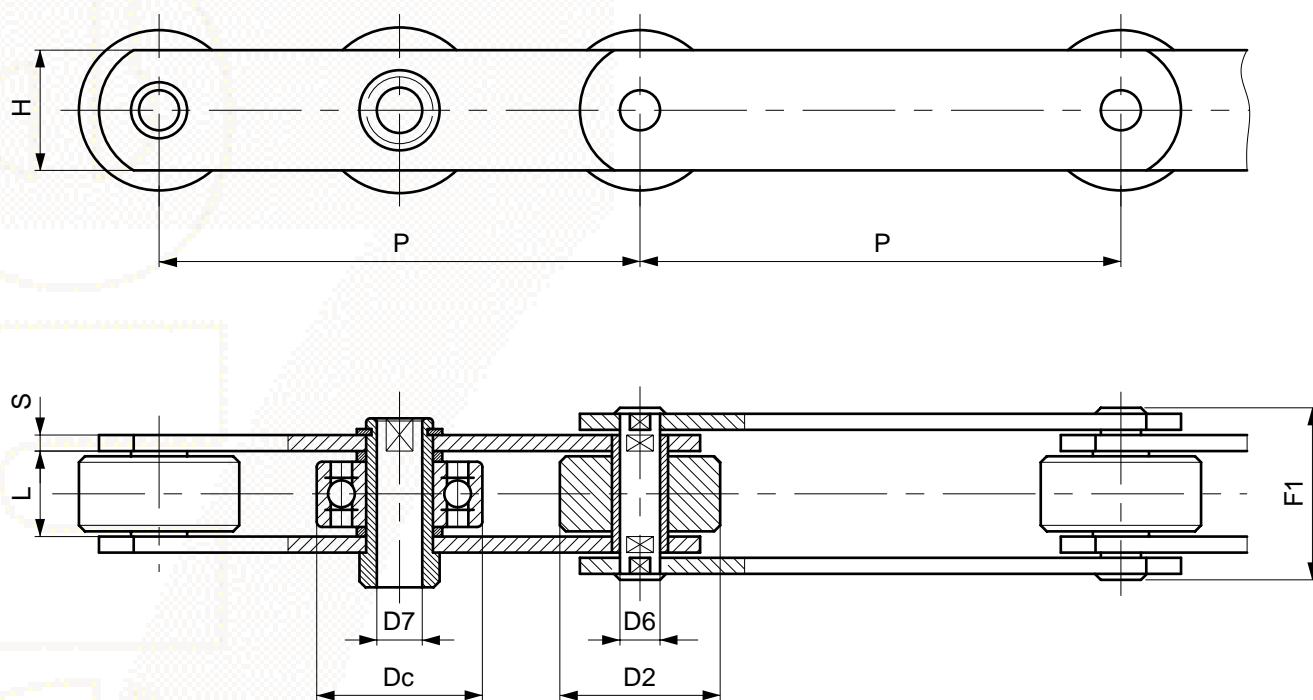

## TRASPORTATORI BILANCELLE

Catena N.	P mm	L mm	D2 mm	D6 mm	D7 mm	Dc mm	H mm	S mm	F1 mm	 Carico di rottura N	Note
W3248	80	28	52	18	12	52	35/40	5	55	80.000	
W3513	80	28	52	18	12	52	35/40	5	55	80.000	Rullo su cuscinetto
W4976	140	32	30	21	15	47	40	6	63	170.000	
W4949	152,4	26	60	33	27	62	50	7/5	58	200.000	
W3729	160	32	60	21	15	62	40/45	6	63	140.000	
W4751	160	35	36	25	17	62	45	6	65	180.000	
W3247	180	32	60	21	15	62	40/45	6	63	112.000	
W2498	180	36	70	30	20	72	60	8	77	300.000	
W3064	180	43	70	30	21	72	60	8	84	300.000	
W4937	200	26	60	33	27	62	50	7/5	58	200.000	
W2340	200	36	70	30	20	72	60	8	77	300.000	



# CATENE PER APPLICAZIONI SPECIALI - INDUSTRIA CONSERVIERA

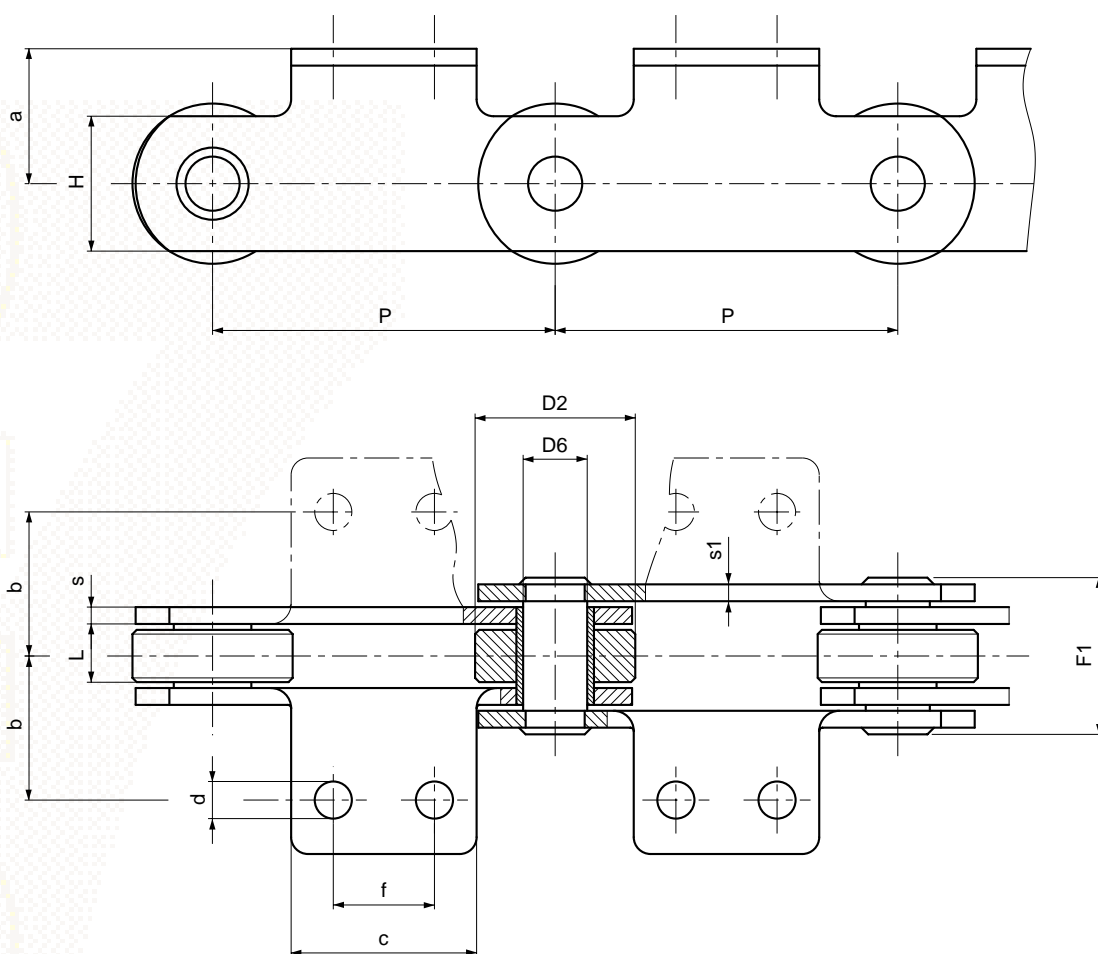

A PERNI PIENI

Catena N.	P mm	L mm	D2 mm	D6 mm	H mm	S/S1 mm	a mm	b mm	c mm	F1 mm	Carico di rottura N
W2689	50	15	31	10	25	4/4	17,5	34	60	36	65.000
500BRA102	50	15	31	10	25	4/4	17,5	34	60	36	65.000
W4216	76,2	15	31,75	14	26,5	4/4	19	38,1	43	37	34.000
W1829	86	14,5	45	14	35	4/4	7,5	37	35	36,5	74.000
W1826	100	15	45	10	25	4/4	15	47,5	70	36	45.000
W4338	100	22	45	12	35	4/4	33,5	40	70	43	100.000
W3776	101,6	19	47,5	19	40	5/4	38	44,5	63,5	44,8	100.000
W3952	101,6	19	47,5	19	40	5/4	30	44,5	63,5	44,8	100.000
W2554/5	101,6	19	47,5	19	40	5/4	40	41	63,5	44,8	100.000

# CATENE PER APPLICAZIONI SPECIALI - INDUSTRIA CONSERVIERA

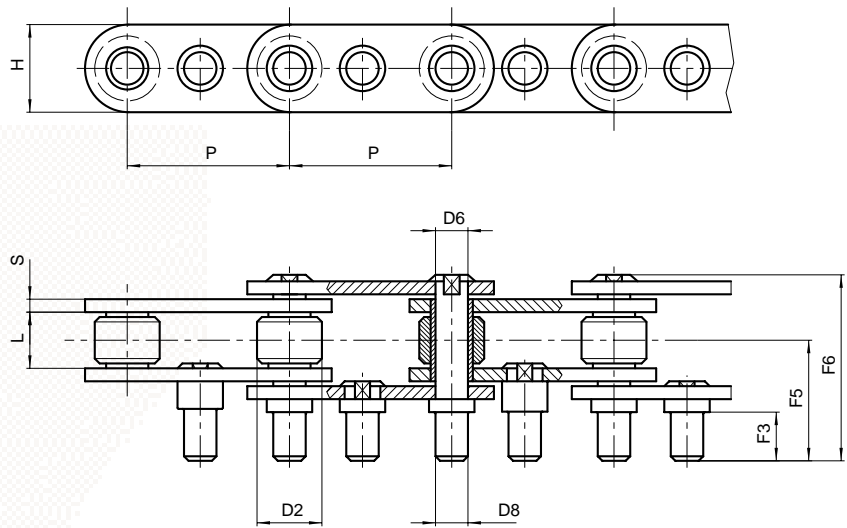

SEPARAPELLI

Catena N.	P mm	L mm	D2 mm	D6 mm	D8 mm	H mm	S mm	F3 mm	F5 mm	F6 mm	Carico di rottura N
W1173	50	15	20	9,85	10	27	4	15	32,5	53,5	75.000
W2938	50	15	20	9,85	10	25	4	15	32,5	57	70.000
W1440	53	16	27	8	8	20	3	17	32,5	53,5	24.000
W1527	53	16	25	8	8	20	3	15	32,5	53,5	50.000

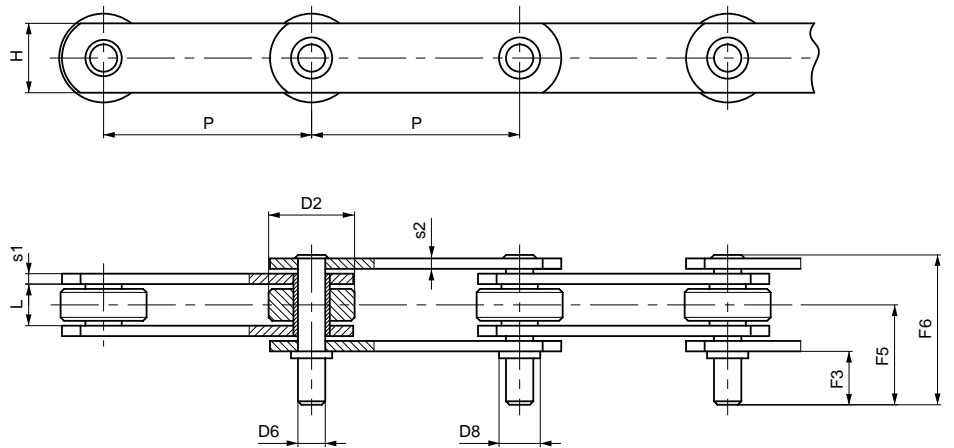

A PERNI SPORGENTI

Catena N.	P mm	L mm	D2 mm	D6 mm	D8 mm	H mm	S1/S2 mm	F3 mm	F5 mm	F6 mm	Carico di rottura N
500D202	50	15	31	12	16	25	4/4	32	48	66	45.000
W1201	75	15	31	9,85	9,85	25	4/4	20	36	54	75.000
W1200	80	15	31	9,85	9,85	25	4/4	20	36	54	75.000
W2010	88,9	15	31,75	9,85	9,85	25	4/4	20	36	53,5	45.000
W1746	88,9	19	47,5	19,1	/	40	5/4	25	44,2	65,5	100.000
W2832	100	15	32	9,85	15	25	4/4	20	36	53,5	45.000
W1137	101,6	15	38	12	16	25	4/4	25	53,5	72	40.000



## CATENE PER APPLICAZIONI SPECIALI - INDUSTRIA CONSERVIERA

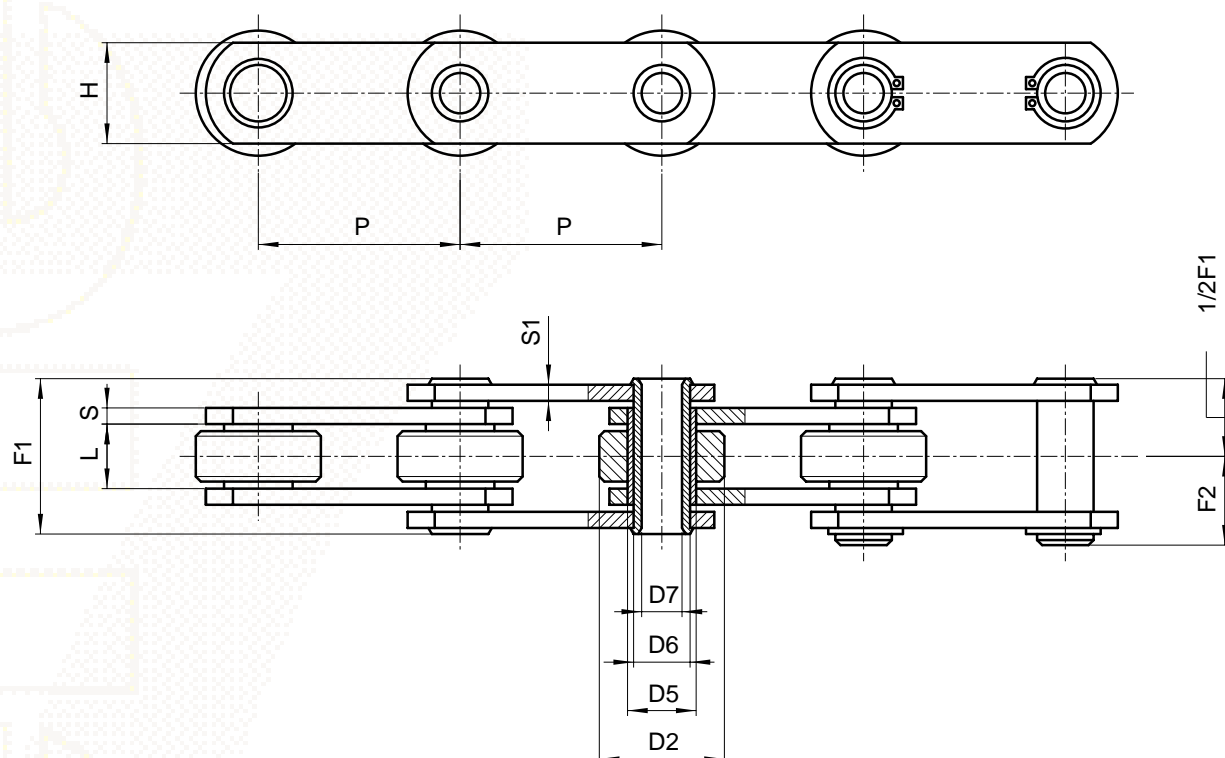

### A PERNI FORATI

Catena N.	P mm	L mm	D2 mm	D5 mm	D6 mm	D7 mm	H mm	S/S1 mm	F1 mm	Carico di rottura N
W2003	50	11,5	25	11	9	6,2	20	2,5/2,5	25	25.000
W4886RZV**	76,2	19	47,5	23	19	13,5	40	5/4	44,75	108.000
W1830	86	14,5	45	25	20	14,4	35	4/3	34	50.000
W2058	86	15	45	25	20	14,4	35	5/4	38,5	60.000
W3149	101,6	19	47,5	23,5	19	13,25	40	5/4	43,5	125.000
W2009	101,6	31	47,5	23	18	13,5	40	5/4	43	60.000
W4890RZV**	101,6	19	47,5	23	19	13,5	40	5/4	44,75	108.000
W4894RZV**	127	19	47,5	23	19	13,5	40	5/4	44,75	108.000
W4769	127	19	47,5	23	19	13,5	40	5/4	44,75	69.000
W4962SS*	127	19	47,5	23	19	13,5	40	5/4	44,75	60.000

\* catena in acciaio INOX

\*\* esecuzione zincata verde



# CATENE PER APPLICAZIONI SPECIALI - FORNI COTTURA ALIMENTI

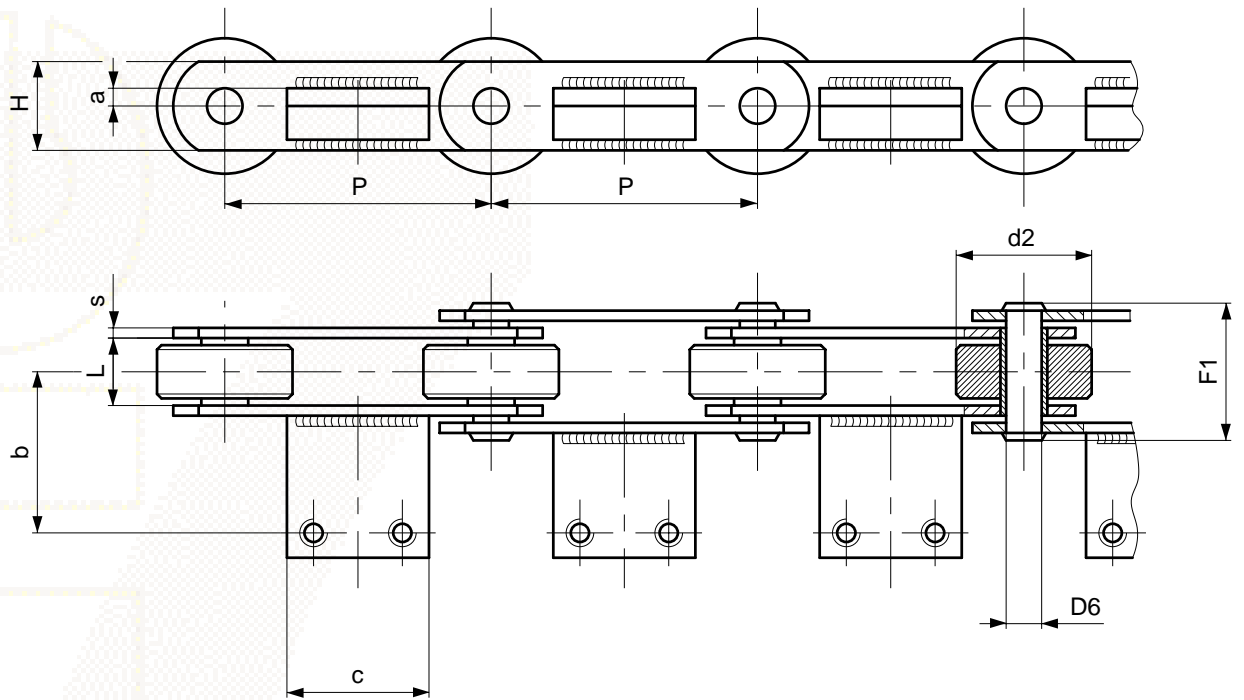

## A PERNI PIENI

Catena N.	P mm	L mm	D2 mm	D6 mm	H mm	S mm	F1 mm	a mm	b mm	c mm	Carico di rottura N	Note
W1596	75	22	45	12	35	4	43	17,5	50	50	100.000	Attacchi piegati
W2224	100	22	60	18	40	4	43,5	6	45	50	115.000	
W3636	100	22	18	12	30	4	43,5	/	/	/	64.000	Senza attacchi
W3030	100	25	60	14	50	5	57,5	/	/	/	150.000	Senza attacchi
W4983	100	36	65	22	50	6	75	4	45	60	190.000	
W2784	100	40	60	18	40	6	71	6	58	60	150.000	
W5062	100	40	60	18	40	6	71	6	58	50	150.000	
W4034	125	22	40	12	30	4	43,5	15	77	80	80.000	
W4929R	125	37	70	20	50	7	78	9	/	58	260.000	Att. senza fori
W4543	355,6	49	60	16	40	6	80,5	1	63,5	283	140.000	

# CATENE PER APPLICAZIONI SPECIALI - INDUSTRIA COTTURA ALIMENTI

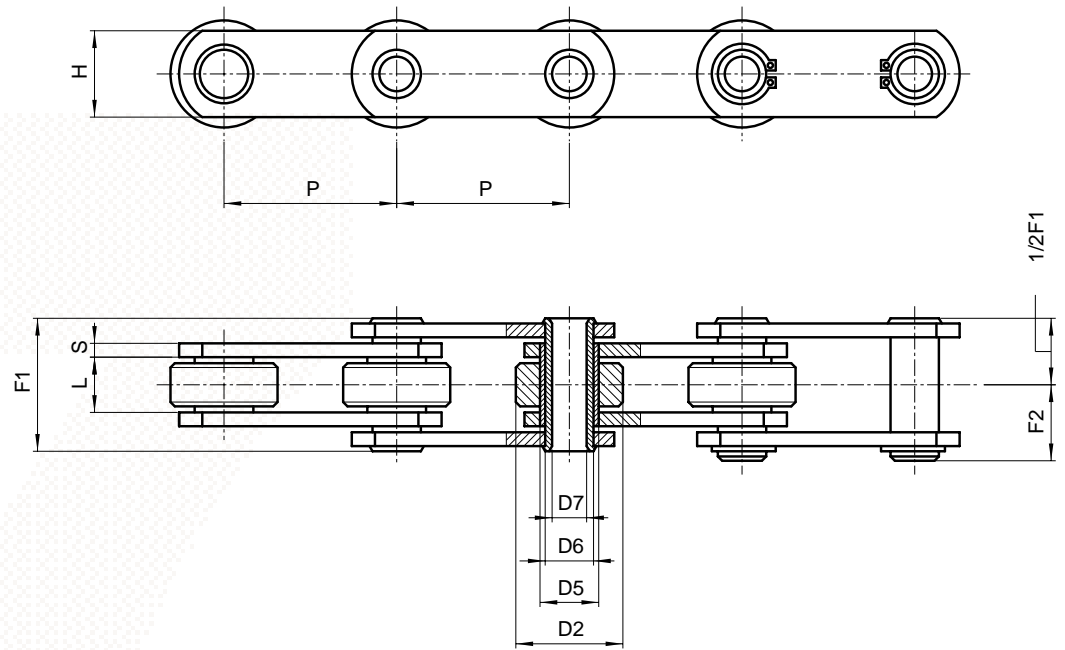

A PERNI FORATI

Catena N.	P mm	L mm	D2 mm	D5 mm	D6 mm	D7 mm	H mm	S mm	F1 mm	F2 mm	Carico di rottura N	Note
W1368	50	11,5	31,75	17,12	10	9,7	25	3	28	17,1	40.000	**
500CRP	50	15	31	17	14	10,2	25	4	35	19,5	65.000	
W3835	75	22	45	24	18	12,4	35	4	44	27,5	120.000	***
W2467	100	25	60	26	18	10,2	40	5	51	33	135.000	
W4858	100	36	65	30,8	22	10,5	50	6	75	/	190.000	
W4445	152,4	25,4	64	31,8	25	19,5	50	7/5	56	30	150.000	

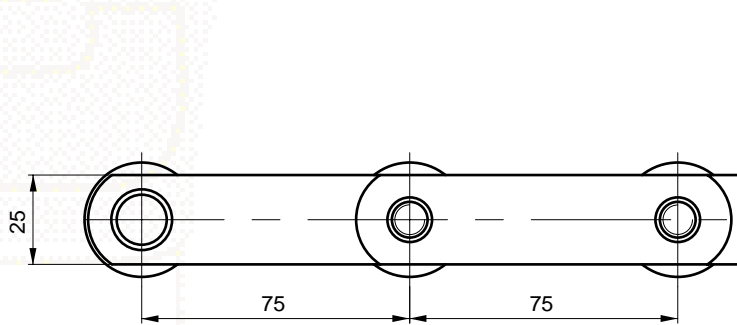

COTTURA PANE

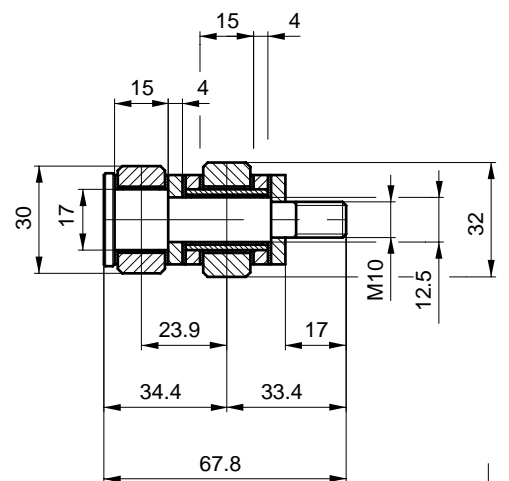

Catena P. 75x15x32 øR

Esente lubrificazione e manutenzione

Temperatura di esercizio: 250-300°C

\*\* Cat. a perni pieni e perni forati ogni... passi

\*\*\* Perni forati ogni 3 passi





CATENE PER APPLICAZIONI SPECIALI - INDUSTRIA COTTURA ALIMENTI

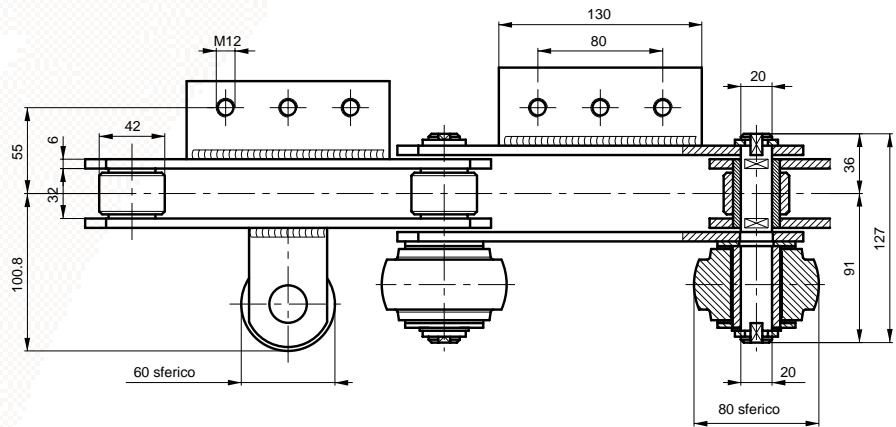
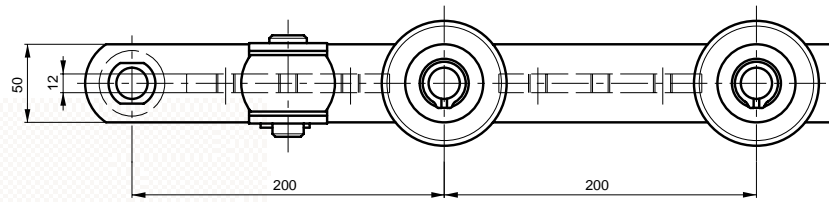

COTTURA PANE

Catena P. 200x32x42 øR

Temperatura di esercizio: 250-300°C

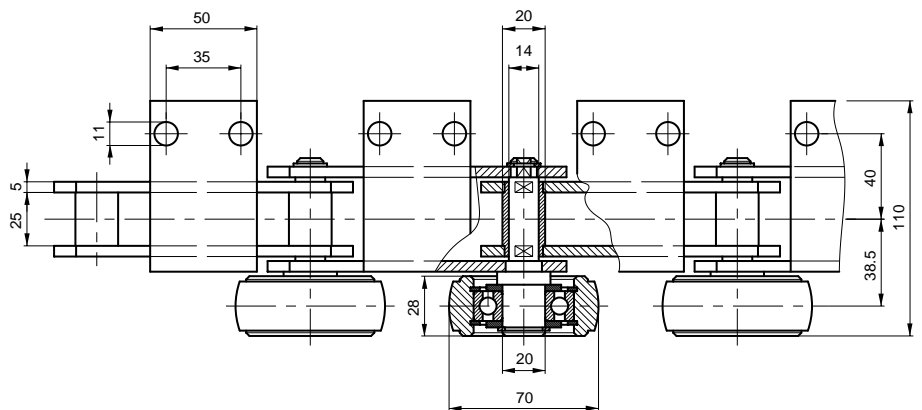
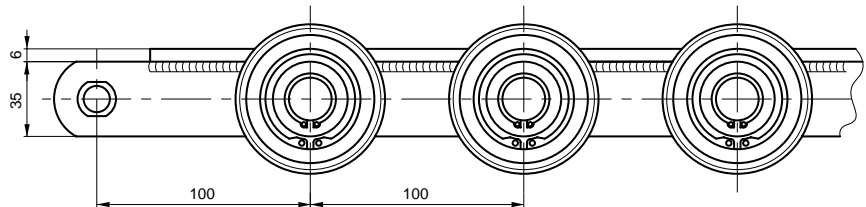

COTTURA PIZZA

Catena P. 100x25x22 øRB

Temperatura di esercizio: 350-400°C



# CATENE PER APPLICAZIONI SPECIALI - INDUSTRIA IMBOTTIGLIAMENTO

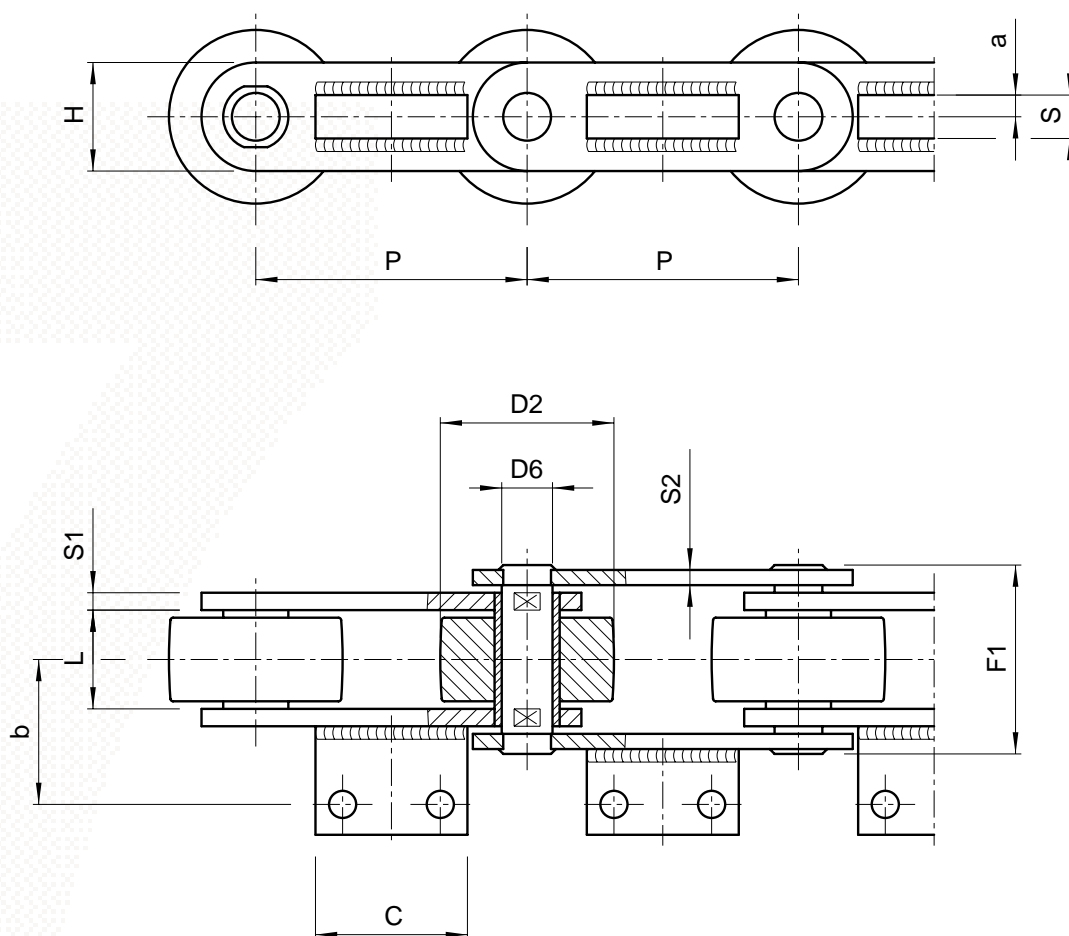

## LAVABOTTIGLIE

Catena N.	P mm	L mm	D2 mm	D6 mm	H mm	S1/S2 mm	F1 mm	a mm	b mm	c mm	s mm	Carico di rottura N	Attacco tipo
W4020CR*	125	42	80	22	50	7/8	79	10	65	70	20	200.000	A2-01
W3820	135	25	75	22	50	5/7	54	25	47	75	5	156.000	A2-01
W4021CR*	140	42	80	22	50	7/8	79	10	65	80	20	200.000	A2-01
W3834	150	25	80	22	50	5/7	54	30	48	80	5	156.000	A2-01
W3819	150	37	90	18	50	7	70	25	52	80	15	160.000	A2-01
W4022CR*	150	42	80	22	50	7/8	79	10	65	90	20	200.000	A2-01
W4502	160	43	85	21	60	8	84	0	64,5	80	20	300.000	A2-01
W4023CR*	173	42	80	22	50	7/8	79	10	65	90	20	200.000	A2-01
W4024CR*	203,2	42	80	22	50	7/8	79	10	65	90	20	200.000	A2-01

\* soluzioni alternative con L = 32 mm



CATENE PER APPLICAZIONI SPECIALI - INDUSTRIA LATERIZI

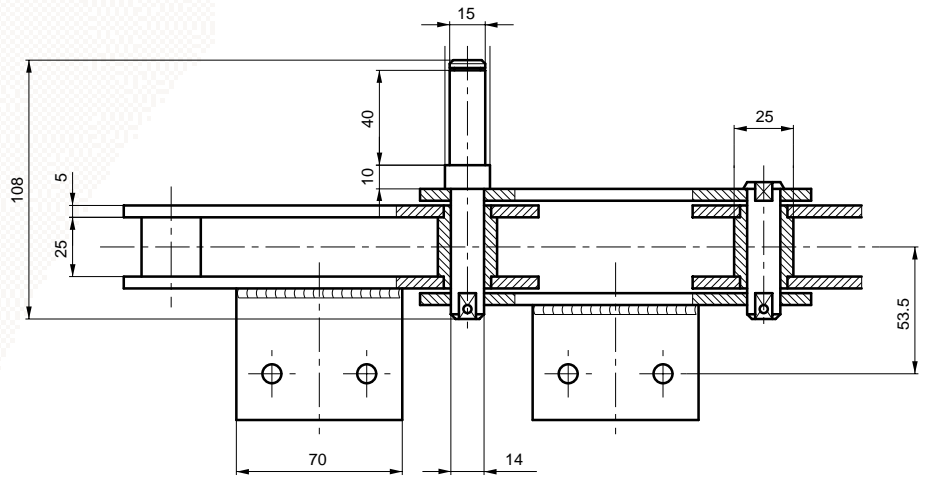
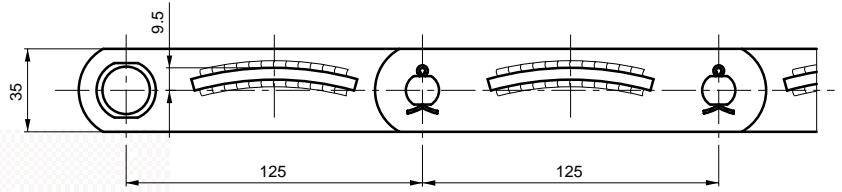

Catena P. 125x25x25 øB



Carico di rottura: 100.000 N

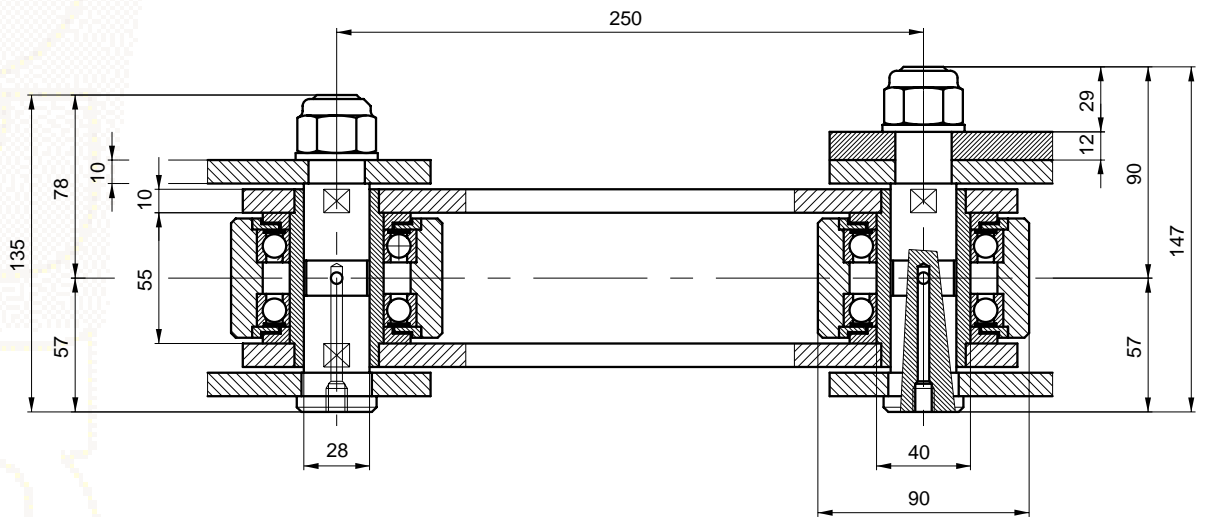

ESCAVATORE  
A TAZZE

Catena P. 250x55x90 øR



Carico di rottura: 500.000 N



# CATENE PER APPLICAZIONI SPECIALI - MACCHINE AGRICOLE

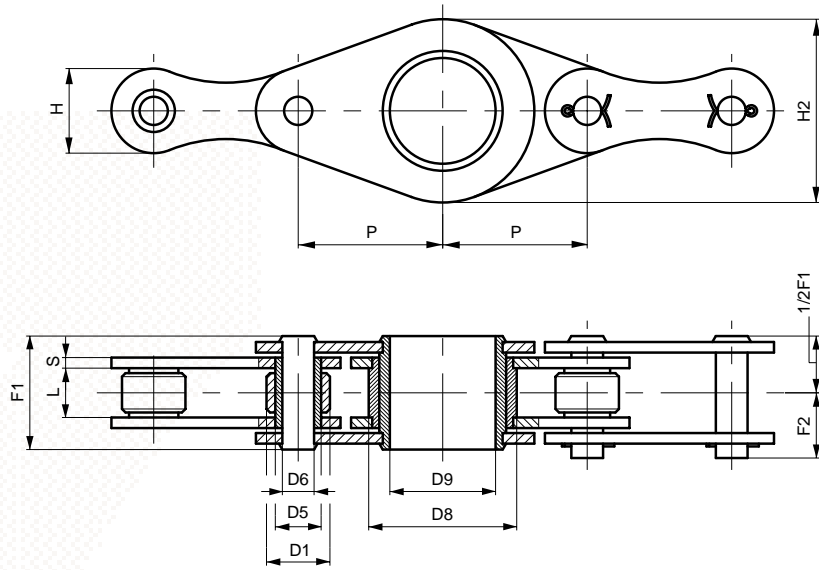

## ROTOPRESSE

Catena N.	P mm	L mm	D1 mm	D5 mm	D6 mm	H mm	H2 mm	S mm	D8 mm	D9 mm	F1 mm	F2 mm	 Carico di rottura N	Note
A5080..	50,8	20	19	13,2	9,6	25,5	63	4	48	35,5	40,5	24	100.000	Attacco ogni 6 passi
A508004..	50,8	20	19	13,2	9,6	25,5	63	4	48	35,5	40,5	24	100.000	Attacco ogni 4 passi

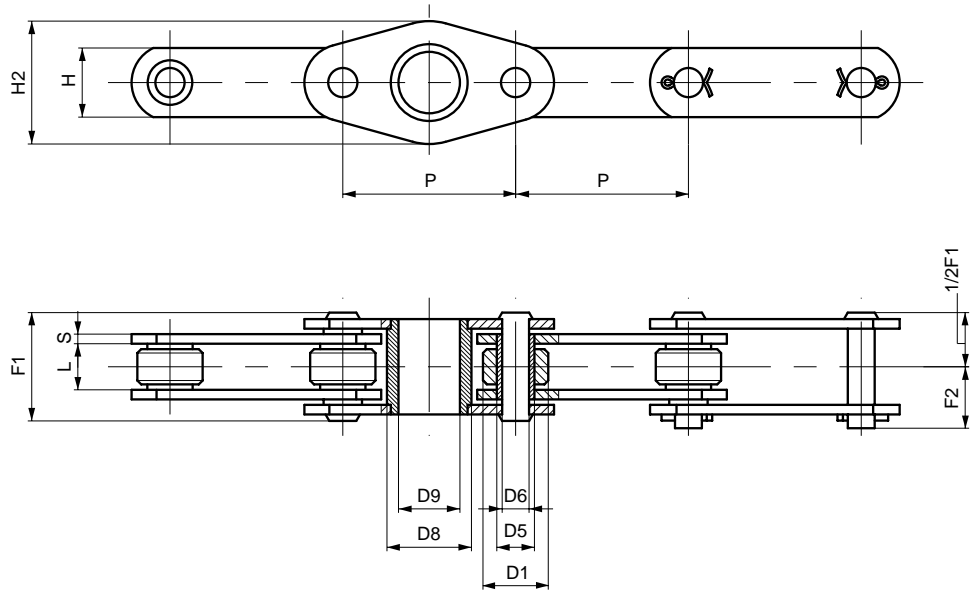

## CARICA FORAGGIO

Catena N.	P mm	L mm	D1 mm	D5 mm	D6 mm	H mm	H2 mm	S mm	D8 mm	D9 mm	F1 mm	F2 mm	 Carico di rottura N	Note
A7020..	70	15	20	13,2	10	25	46	4	32	26	36,6	21	100.000	Attacco ogni 6 passi
A702002..	70	15	20	13,2	10	25	46	4	32	26	36,6	21	100.000	Attacco ogni 2 passi

CATENE PER APPLICAZIONI SPECIALI - MAGAZZINI ROTANTI

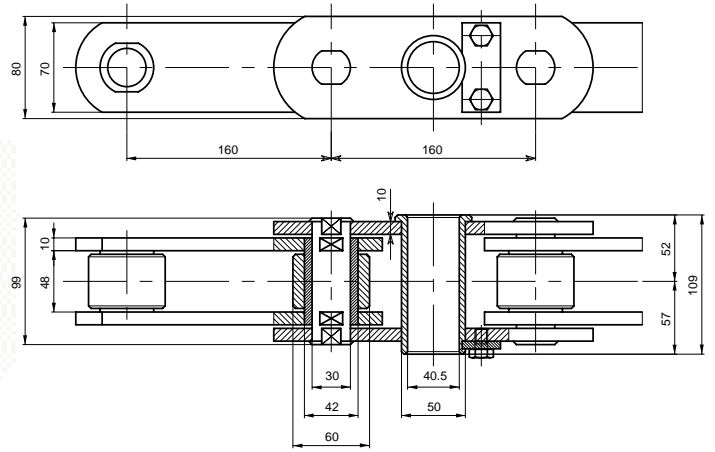

Catena P. 160x48x60 øR



Carico di rottura: 520.000 N

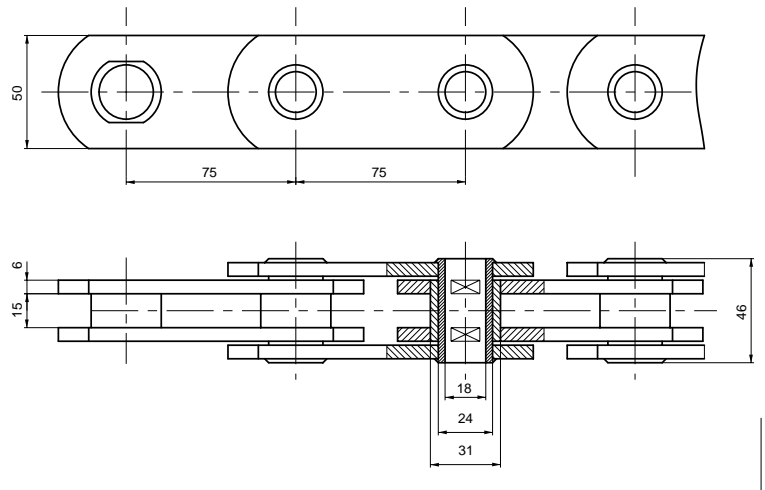

Catena P. 75x15x31 øB



Carico di rottura: 120.000 N

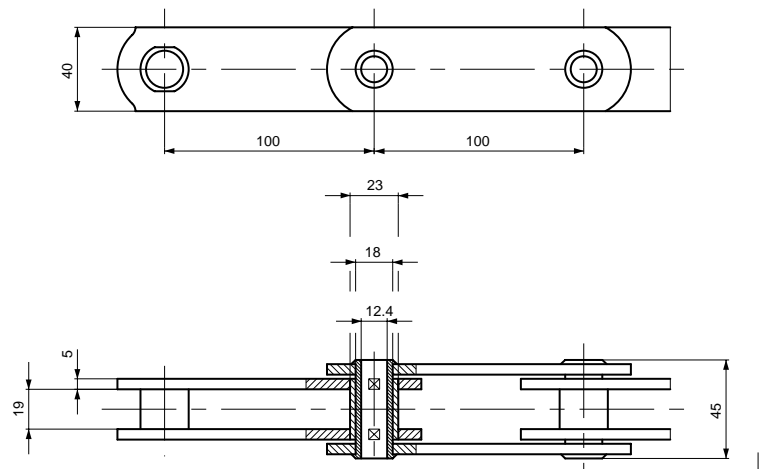

Catena P. 100x19x23 øB



Carico di rottura: 100.000 N



# CATENE PER APPLICAZIONI SPECIALI - INDUSTRIA DEL MOBILE

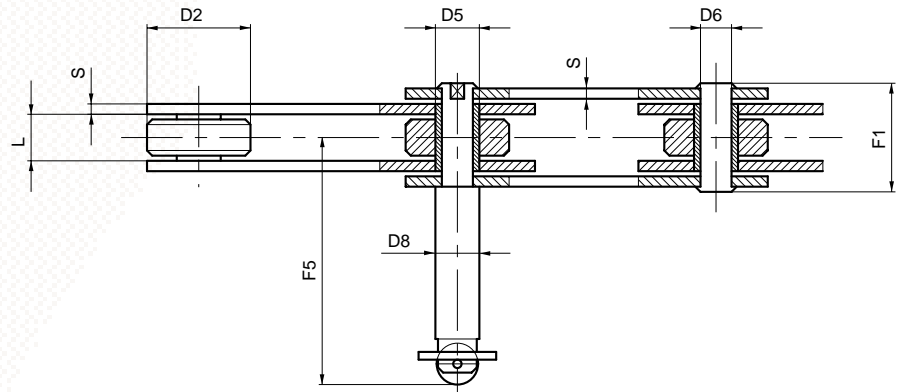
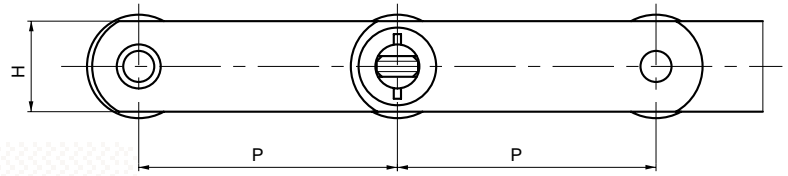

VERNICIATURA

Catena N.	P mm	L mm	D2 mm	D5 mm	D6 mm	D8 mm	H mm	S mm	F1 mm	F5 mm	Carico di rottura N
W2030	75	18	40	17	12	17	35	4	39	94	75.000
W1555	100	18	40	17	12	17	35	4	39	94	75.000

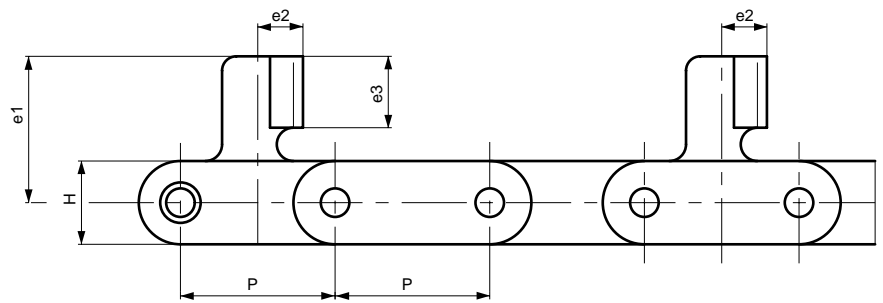

ESSICCAZIONE

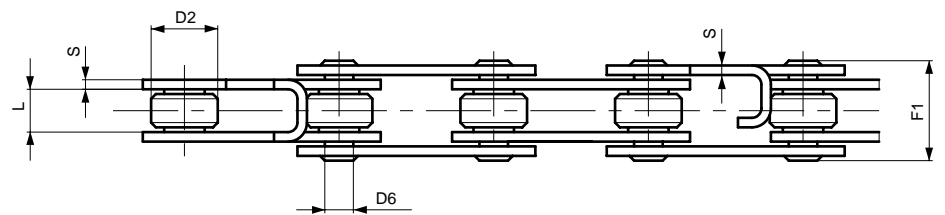

Catena N.	P mm	L mm	D2 mm	D6 mm	H mm	S mm	F1 mm	e1 mm	e2 mm	e3 mm	Carico di rottura N
W2439	65	18	28	12	35	4	39	55,5	8	25	125.000
W2120R	75	15	40	12	35	4	36,5	55,5	8	25	125.000
W1127R03	65	18	28	12	35	4	40	61,5	12	30	125.000
W2756R	60	15	31	12	35	4	36	55,5	8	25	125.000



CATENE PER APPLICAZIONI SPECIALI - INDUSTRIA PRODUZIONE PANNELLI POLIURETANO

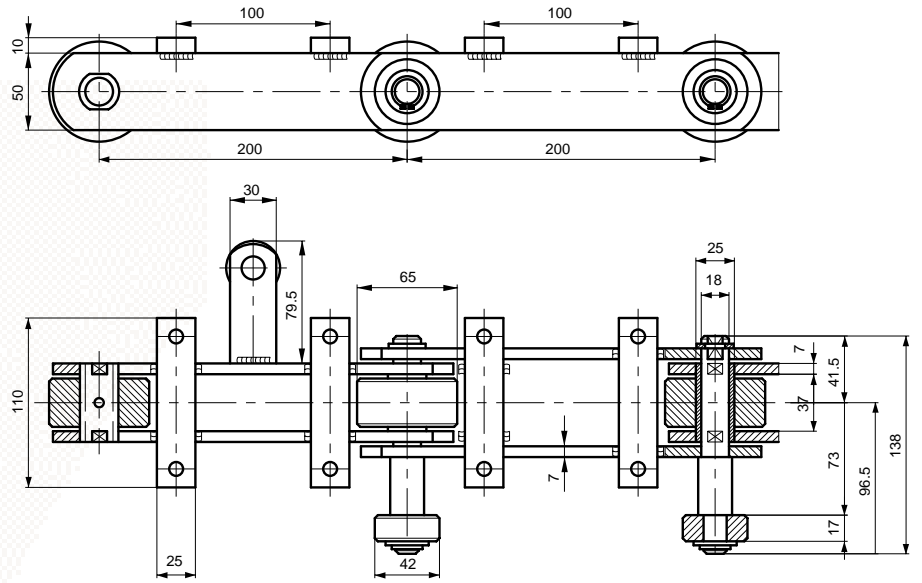

TUNNEL DI  
CONDIZIONAMENTO

Catena P. 200x37x65 øR



Carico di rottura: 210.000 N

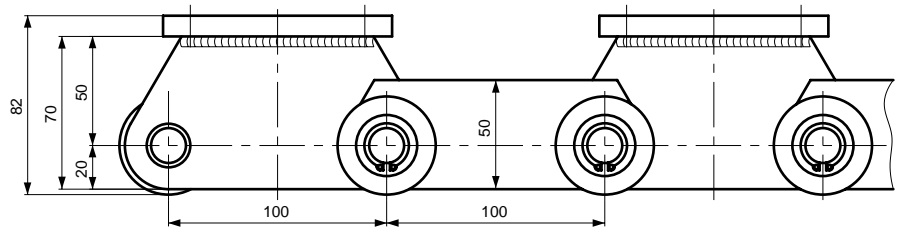

TUNNEL DI  
CONDIZIONAMENTO

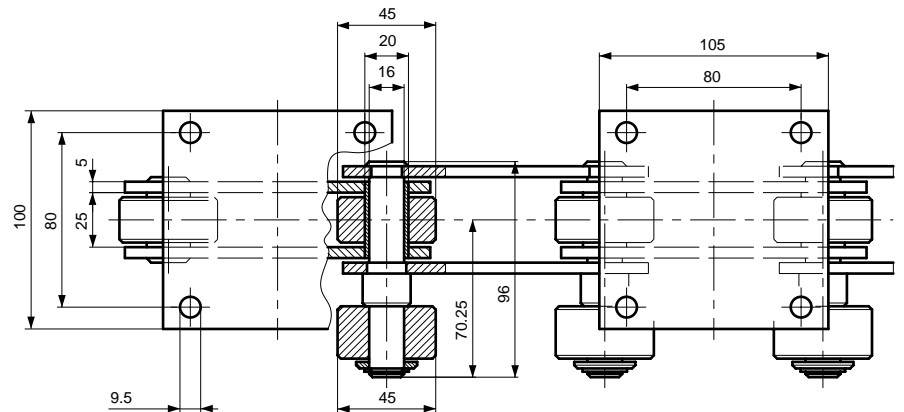

Catena P. 100x25x45 øR



Carico di rottura: 210.000 N



# CATENE PER APPLICAZIONI SPECIALI - SMALTIMENTO-RECUPERO CARTA DA MACERO E RIFIUTI

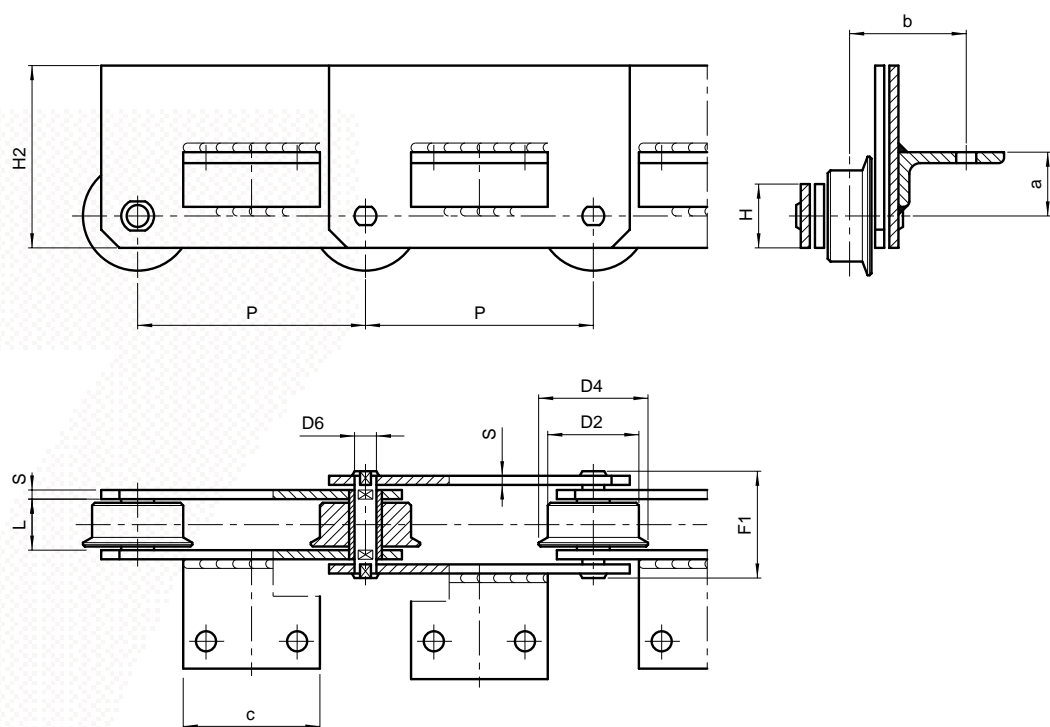

## A PERNI PIENI

Catena N.	P mm	L mm	D2 mm	D4 mm	D6 mm	H mm	H2 mm	S mm	a mm	b mm	F1 mm	Carico di rottura N	Attacco tipo
W1743	100	24	40	/	12	35	/	4	26	38,5	45	75.000	A1-01
W4563•	125	25	40	/	14	35	/	5	-2,5	41	51,5	100.000	A2-01
W4122	125	28	50	65	12	35	100	5	35	64	54,5	80.000	A2-01
W4123•	125	28	50	65	12	35	100	5	-5	64	54,5	80.000	A2-01
W4122A	125	28	50	65	12	35	100	5	35	48	54,5	80.000	A2-01
W4123A•	125	28	50	65	12	35	100	5	-7	48	54,5	80.000	A2-01
W4123B•	125	28	50	65	12	35	100	5	-7	48	54,5	80.000	A2-02
W3946	200	32	60	/	15	40	90	6	/	/	63	112.000	senza attacchi
W3946R	200	32	60	75	15	40	90	6	/	/	63	180.000	senza attacchi
W4587	200	36	65	80	20	50	100	8	26	70	77	175.000	A2-01
W4124	200	37	70	90	18	50	120	7	55	80	72	160.000	A2-01
W4125•	200	37	70	90	18	50	120	7	-5	80	72	160.000	A2-01
W4639•	200	37	70	90	18	50	80	7	-10	80	72	160.000	A2-01
W4124R	200	37	70	90	18	50	120	7	55	80	72	260.000	A2-01
W4125R•	200	37	70	90	18	50	120	7	-5	80	72	260.000	A2-01

\* angolare solo sulle piastre interne  
 • pos. attacco sotto mezzeria





CATENE PER APPLICAZIONI SPECIALI - STOCCAGGIO-TRASPORTO CEREALI DIN 8167

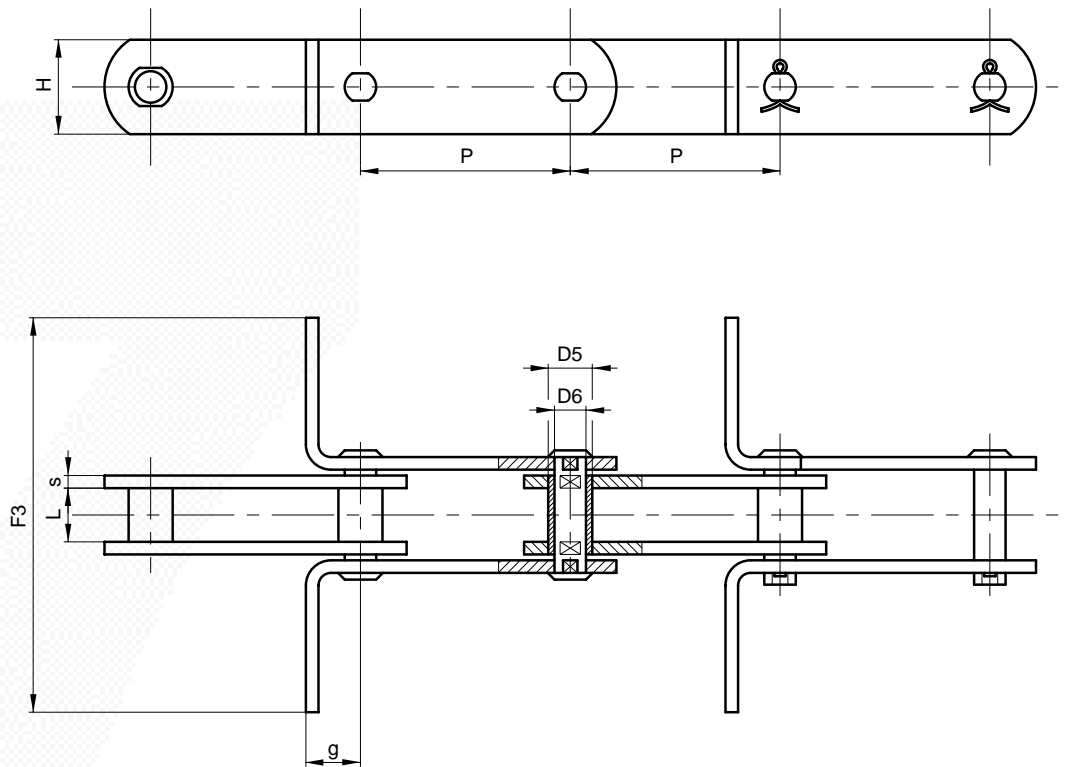

A PIASTRE  
RASCHIANTI

Catena N.	P mm	L mm	D5 mm	D6 mm	H mm	s mm	g mm	F3 mm	Carico di rottura N	Peso cat. kg/m ●
MR56	100	24	15	10	30	4	20	*	56.000	2,8
"	125	24	"	"	"	"	"	*	"	2,6
MR80	100	28	18	12	35	5	25	*	80.000	4,3
"	125	28	"	"	"	"	"	*	"	4
"	150	28	"	"	"	"	"	*	"	3,7
MR112	100	32	21	15	40	6	35	*	112.000	6,2
"	125	32	"	"	"	"	"	*	"	5,7
"	150	32	"	"	"	"	"	*	"	5,3
MR160	100	37	25	18	50	7	40	*	160.000	9,7
"	125	37	"	"	"	"	"	*	"	8,9
"	150	37	"	"	"	"	"	*	"	8,2
MR224	125	43	30	21	60	8	44	*	224.000	13
"	150	43	"	"	"	"	"	*	"	12
"	200	43	"	"	"	"	"	*	"	11
MR315	150	48	36	25	70	10	50	*	315.000	18,3
"	200	48	"	"	"	"	"	*	"	16,7
"	250	48	"	"	"	"	"	*	"	15,6

Versioni alternative:  
 - accoppiate da 1 o 2 lati  
 - esecuzione fori su pale raschianti  
 - acciaio inossidabile

● senza pale raschianti  
 \* dimensioni libere

# CATENE PER APPLICAZIONI SPECIALI - STOCCAGGIO-TRASPORTO CEREALI DIN 8165

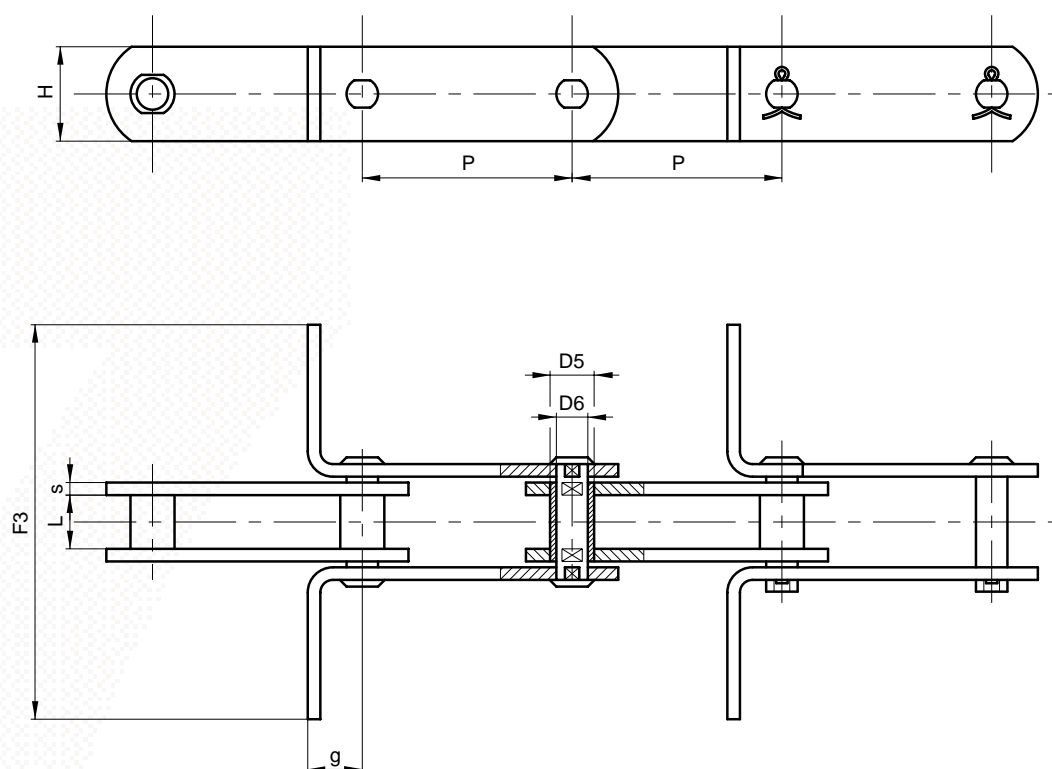

## A PIASTRE RASCHIANTI

DIN N.	Catena N.	P mm	L mm	D5 mm	D6 mm	H mm	s mm	g mm	F3 mm	Carico di rottura N	Peso cat. kg/m ●
FV40	CR42	80	18	15	10	25	3	25	*	42.000	1,9
"	"	100	"	"	"	"	"	"	*	"	1,7
"	"	125	"	"	"	"	"	"	*	"	1,6
FV63	CR64	100	22	18	12	30	4	25	*	64.000	3
"	"	125	"	"	"	"	"	"	*	"	2,7
"	"	150	"	"	"	"	"	"	*	"	2,4
FV90	CR100	100	25	20	14	35	5	30	*	100.000	4,5
"	"	125	"	"	"	"	"	"	*	"	4,2
"	"	150	"	"	"	"	"	"	*	"	4
FV112	CR120	100	30	22	16	40	6	35	*	120.000	6,7
"	"	125	"	"	"	"	"	"	*	"	6
"	"	150	"	"	"	"	"	"	*	"	5,5
FV140	CR145	100	35	26	18	45	"	38	*	145.000	7,4
"	"	125	"	"	"	"	"	"	*	"	6,7
"	"	150	"	"	"	"	"	"	*	"	6
FV180	CR190	125	45	30	20	50	8	44	*	190.000	10,5
"	"	150	"	"	"	"	"	"	*	"	10,2
"	"	200	"	"	"	"	"	"	*	"	9,6
FV250	CR275	125	55	36	26	60	"	50	*	275.000	13,4
"	"	150	"	"	"	"	"	"	*	"	12,3
"	"	200	"	"	"	"	"	"	*	"	11,3

Versioni alternative:  
 - accoppiate da 1 o 2 lati  
 - esecuzione fori su pale raschianti  
 - acciaio inossidabile

● senza pale raschianti  
 \* dimensioni libere



# CATENE PER APPLICAZIONI SPECIALI - TABACCO

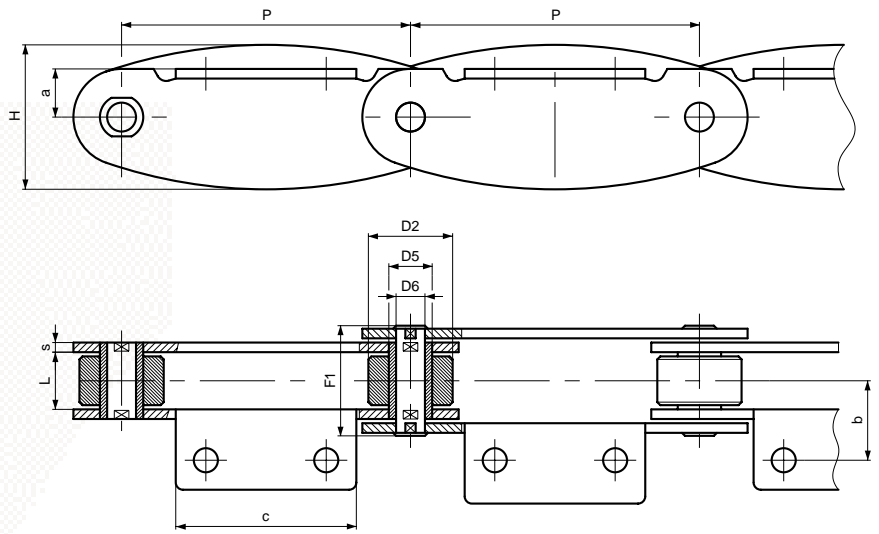

Catena N.	P mm	L mm	D2 mm	D6 mm	H mm	S mm	F1 mm	a mm	b mm	c mm	Carico di rottura N
W3571	120	22	35	12	60	4	43	20	33	75	90.000

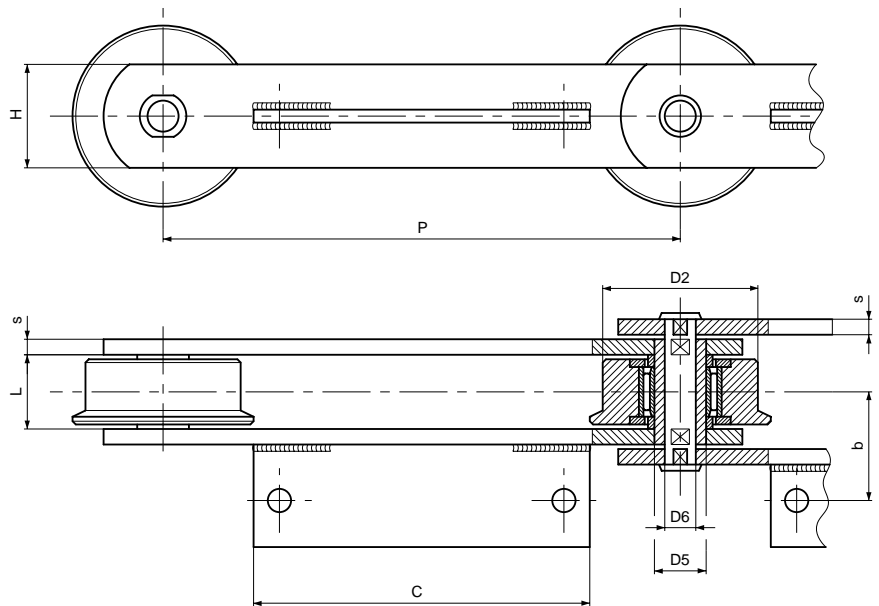

Catena N.	P mm	L mm	D2 mm	D6 mm	H mm	S mm	F1 mm	a mm	b mm	c mm	Carico di rottura N
W3616	200	28	60/70	12	40	5	55	2,5	42	130	60.000
W4088A	200	28	50/60	14	40	5	55	-2,5	40	110	130.000
W3840AR	200	37	60/70	20	40	5	64	2,5	46,5	130	150.000
W4919SS*	200	37	60/70	15	40	5	64	2,5	46,5	130	90.000
W4664	200	38	67/82	15	45	6	69	-2,5	47	110	180.000

\* catena in acciaio inox



# CATENE PER APPLICAZIONI SPECIALI - TABACCO

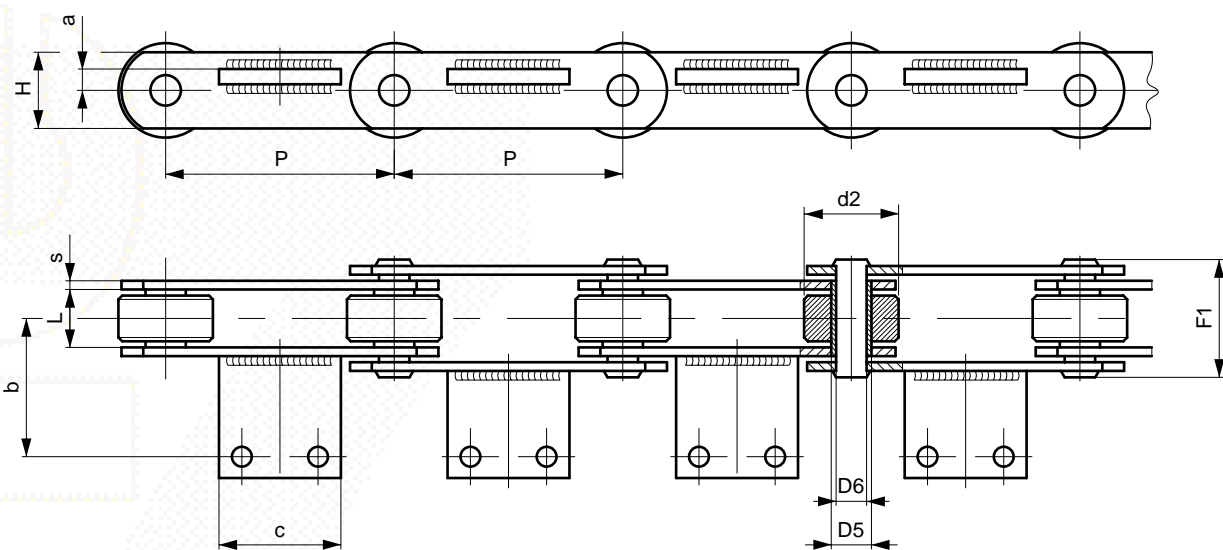

## TUNNEL ESSICAZIONE

Catena N.	P mm	L mm	D2 mm	D6 mm	H mm	S mm	F1 mm	a mm	b mm	c mm	 Carico di rottura N	Note
W3977	75	15	31	10	25	4	36	7	33	40	45.000	
W1383	100	15	55	12	30	4	36	23	40	50	70.000	
W4010	100	26,5	50	12,6	35	5	54	6	41,5	55	100.000	
W3596R	100	26,5	50	12	35	5	54	-14	49,5	35	100.000	
W3458R	100	28	50	14,4	35	5	54,5	14	49,5	35	130.000	
W2988CR	200	26,5	60	16	40	5	54	2,5	43,5	130	150.000	
W2520	200	28	65	18	50	6	59	13	53	60	160.000	
W4088	200	28	50/60	12	40	5	59	-2,5	40	110	100.000	Rullo flangiato
W3808	200	37	70	18	50	7	72	3	62	115	260.000	
W3840R	200	37	60/70	12,4	40	5	63,5	2,5	46,5	130	110.000	Rullo flangiato
W3782	200	38,5	100/112	30	80	10/12	91	3	73	95	850.000	Rullo flangiato
W3790	200	38,5	100/112	36	90	12	97	-3,5	73	95	1.600.000	Rullo flangiato

# CATENE PER APPLICAZIONI SPECIALI - EVACUAZIONE-FILTRAZIONE TRUCIOLI

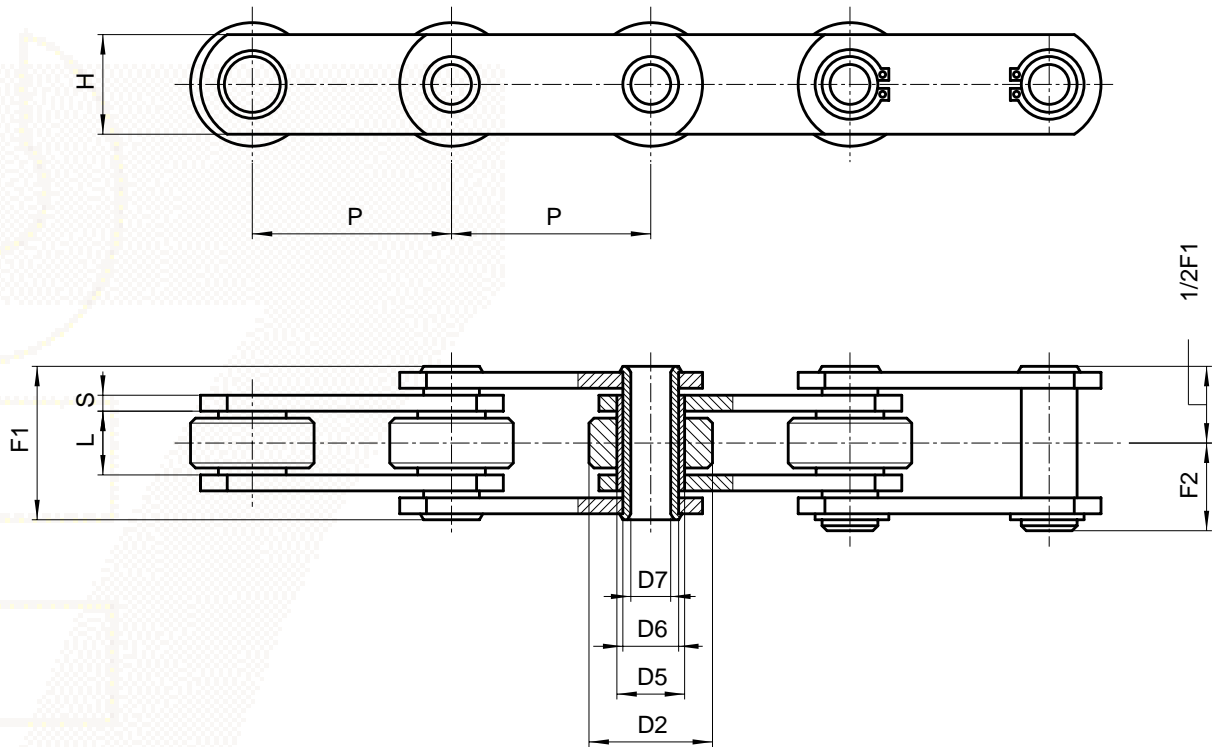

## A PERNI FORATI

Catena N.	P mm	L mm	D2 mm	D5 mm	D6 mm	D7 mm	H mm	S mm	F1 mm	F2 mm	Carico di rottura N	Peso cat. kg/m
C2059	31,75	9,53	19,05	10,2	7,02	5,12	15	2	20,1	11,5	19.600	1,2
W2056	38,1	12,7	22,23	11	9	6,2	18	2,5	25,5	13,75	26.500	1,9
3520Z	35	16	20	17	14	10,2	26	2,5	30	16,7	25.000	2,2
W1667	40	9	22	12	9	6,2	18	2,5	23	13	15.500	1,7
W1948	40	13	25	15	12	8,9	22	3	29	16,7	21.000	2,4
400C ♦	50	15	31	17	14	10,2	25	3	31	17,5	35.000	3
W3635	50	15	31	17	14	10,2	25	3	31	17,5	35.000	3
500C	50	15	31	17	14	10,2	25	4	35	19,5	40.000	3,6
500CSS*	50	15	31	17	14	10,5	25	4	36	19,5	35.000	3,6
W4086Z	50	15	40	17	14	10,5	25	4	36	19,5	40.000	3,8
W2795	50	11,5	25	16	13,2	10,5	23	2,5	25	15	16.000	1,8
W2137R	63	15	40	/	16	12,3	28,5	4	35	20	80.000	4,7
W4601	63	21,5	40	/	16	10,5	28,5	4	42	22	50.000	4,7
W5048	63	18	40	17	14	10,2	28	4	38	20,5	50.000	4,1
6540C	65	18	40	17	14	10,2	25	4	38	21	40.000	4,8
701C	75	22	40	23	18	12,2	35	4	42	24	60.000	4,6
W4671R	75	18	40	/	20	15,2	30	4	38,5	21,5	55.000	4,7
703C	100	22	40	23	18	12,2	35	4	42	24	60.000	4,6
704C	125	22	40	23	18	12,2	35	4	42	24	60.000	4,2
W1521/1 ▲	125	30	60/76	25	20	14,5	40	5	56	31	70.000	9
ZC150C1524X	152,4	25,4	66,7	33	26,9	20,1	50	7/5	58	34,5	150.000	9,7

- \* catena in acciaio inox
- ♦ catena con piastre sagomate
- ▲ catena a rulli flangiati



CATENE PER APPLICAZIONI SPECIALI - EVACUAZIONE-FILTRAZIONE TRUCIOLI

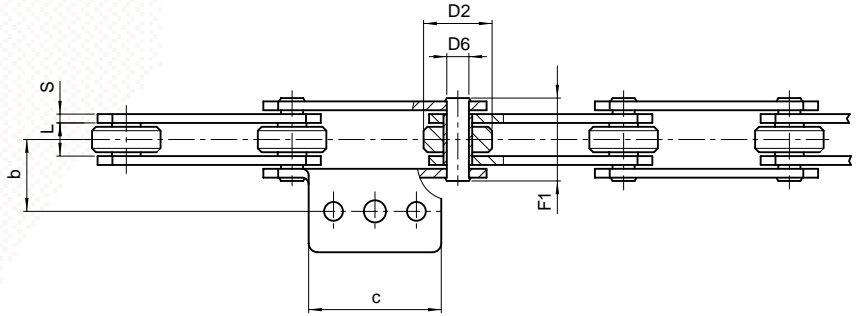
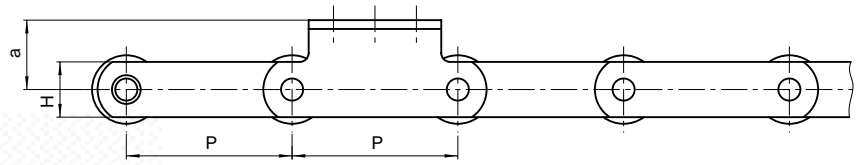

A PERNI PIENI

Catena N.	P mm	L mm	D2 mm	D6 mm	H mm	S mm	F1 mm	a mm	b mm	c mm	Carico di rottura N	Peso cat. kg/m
C2052A204	31,75	9,6	19	5,1	15,1	2	20,4	11,1	15,9	25,4	26.500	1,3
W4218	42	22	18	5,7	20	4	42,5	35	45	30	32.000	2,9
500	50	15	31	10	25	4	36,6	22	45	45	45.000	3,9
205BA108	50	11,5	25	5,7	18	2,5	25,9	14	33	46	18.000	1,8
703BA310	100	22	40	12	35	4	44	26	38	70	75.000	5

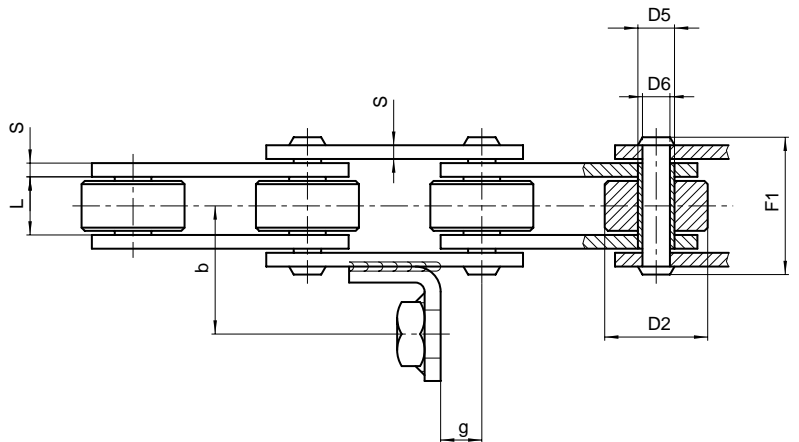
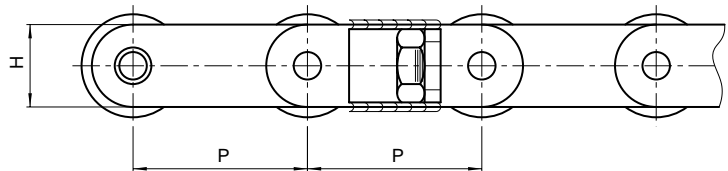

A PERNI PIENI

Catena N.	P mm	L mm	D2 mm	D5 mm	D6 mm	H mm	S mm	F1 mm	g mm	b mm	Carico di rottura N	Peso cat. kg/m
W1949AR	38,1	12,7	22,2	8	6	18	3	30	9	28	38.000	3,3
W4584	63	22	40	17	12	30	4	43	16,5	34	66.000	6,1



# CATENE PER APPLICAZIONI SPECIALI - TUNNEL DI REFRIGERAZIONE

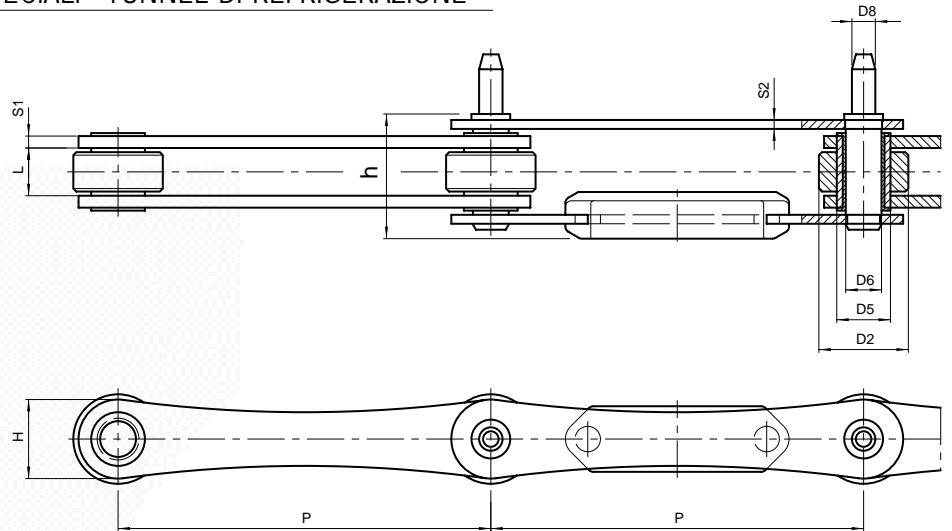

INDURIMENTO

Catena N.	P mm	L mm	D2 mm	D5 mm	D6 mm	D8 mm	H mm	S1/S2 mm	h mm	Carico di rottura N
W4577*	63,5	10	30	18	10	7,9	26,5	3	31,2	30.000
W5071*	95,25	16	30	18	11,9	9	26,5	4/3	36,8	40.000
W4530*	125	14	30	18	11,8	7,9	26,5	4/3	36,5	45.000
W4578*	125	16	30	18	11,8	7,9	26,5	4/3	39,8	40.000
W4967*	127	10	30	16	11,5	7,9	26,5	3	31,3	30.000
W4899*	150	16	30	18	11,9	7,9	26,5	4/3	42,8	40.000

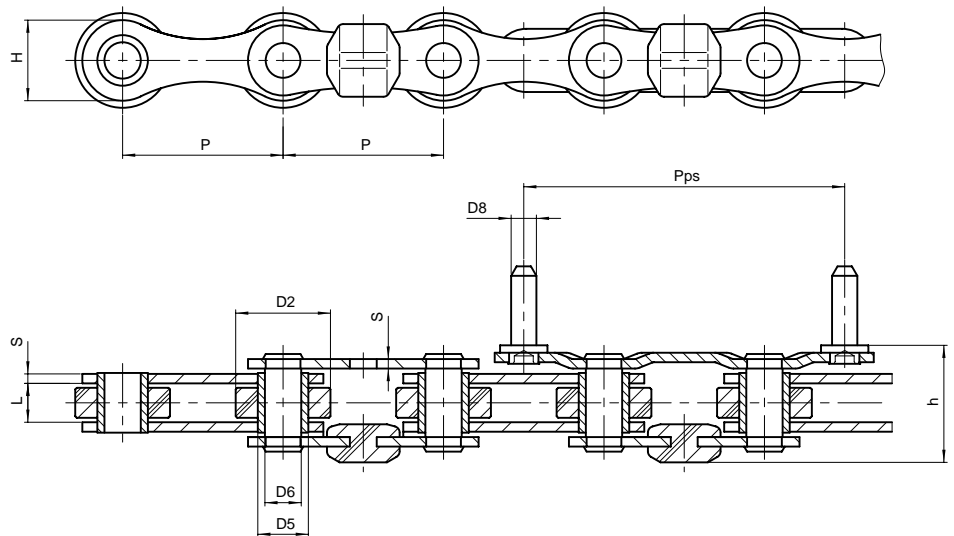

INDURIMENTO

Catena N.	P mm	L mm	D2 mm	D5 mm	D6 mm	D8 mm	H mm	S mm	h mm	Pps mm	Carico di rottura N
W4813*	50,8	10	30	16	11,5	8	25,2	3	29,3	101,6	34.000

\* catena in acciaio inox



# CATENE PER APPLICAZIONI SPECIALI - TUNNEL DI REFRIGERAZIONE

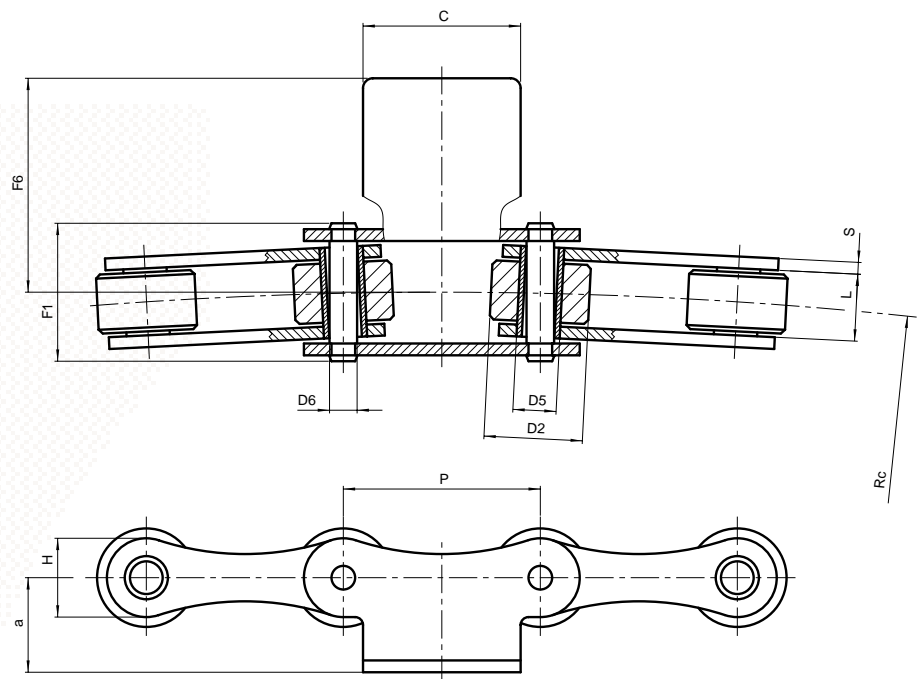

INDURIMENTO

Catena N.	P mm	L mm	D2 mm	D5 mm	D6 mm	H mm	S mm	F1 mm	a mm	c mm	F6 mm	 Carico di rottura N	Note
W1947*	50	17	25	11	7	20	3	33,5	-24	40	54	30.000	Pos. attacco var.

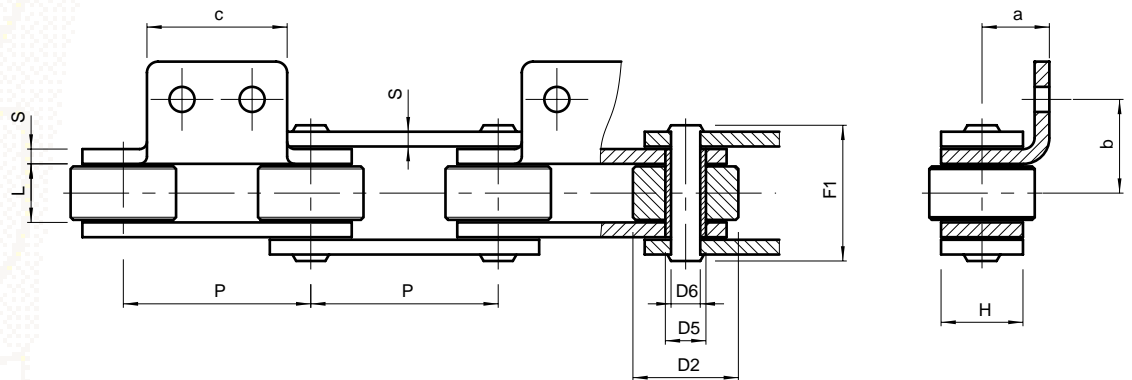

INDURIMENTO

Catena N.	P mm	L mm	D2 mm	D5 mm	D6 mm	H mm	S mm	F1 mm	a mm	b mm	c mm	 Carico di rottura N
W4528ASS*	50,8	15,9	28,6	11	7,9	22,2	4	36,5	18,25	25,4	38	25.000
W4528PSS*	50,8	15,9	28,6	11	7,9	22,2	4	36,5	18,25	17,5	38	25.000

\* in acciaio inox





CATENE PER APPLICAZIONI SPECIALI - TRASPORTATORI CON CATENE STRISCIANTI

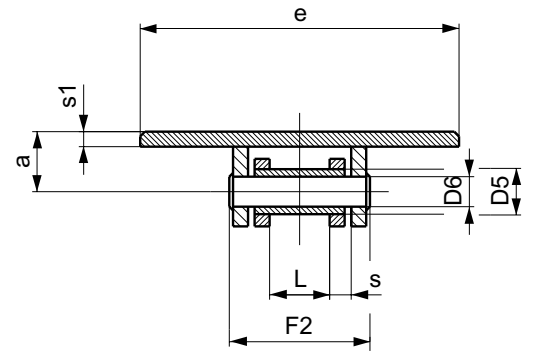
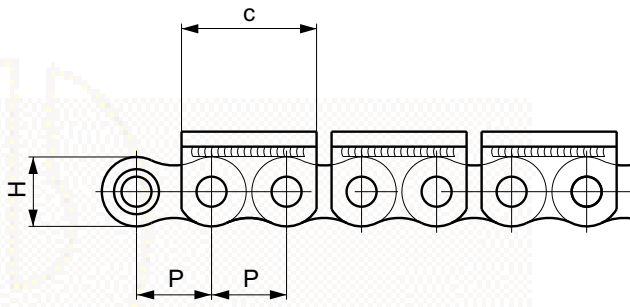

A PERNI PIENI

Catena N.	P mm	L mm	D5 mm	D6 mm	H mm	S mm	F2 mm	a mm	c mm	e mm	s mm	Carico di rottura N	Peso cat. kg/m
TB85	20	16	12	8	18,5	3	36	15,5	36	85	4	20.000	4,7

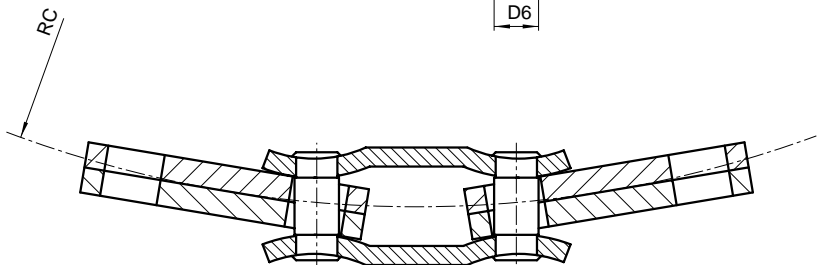
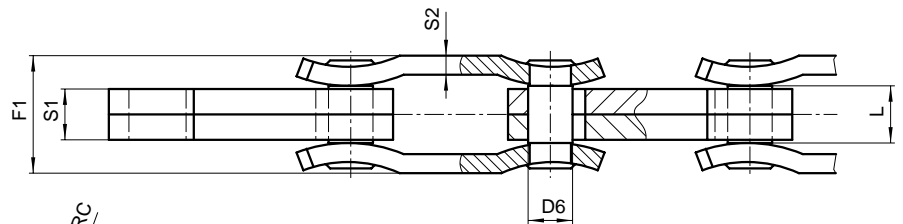
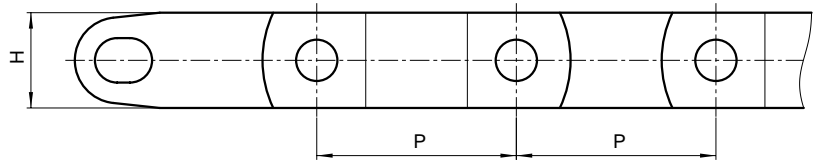

A PERNI PIENI

Catena N.	P mm	L mm	D6 mm	H mm	S1 mm	S2 mm	F1 mm	** RC mm	Carico di rottura N	Peso cat. kg/m
6285	62,85	18	14	30	16	6	38	400	130.000	5,1

\*\* RC raggio minimo di curvatura

## CATENE PER APPLICAZIONI SPECIALI - TRASPORTATORI CURVILINEI

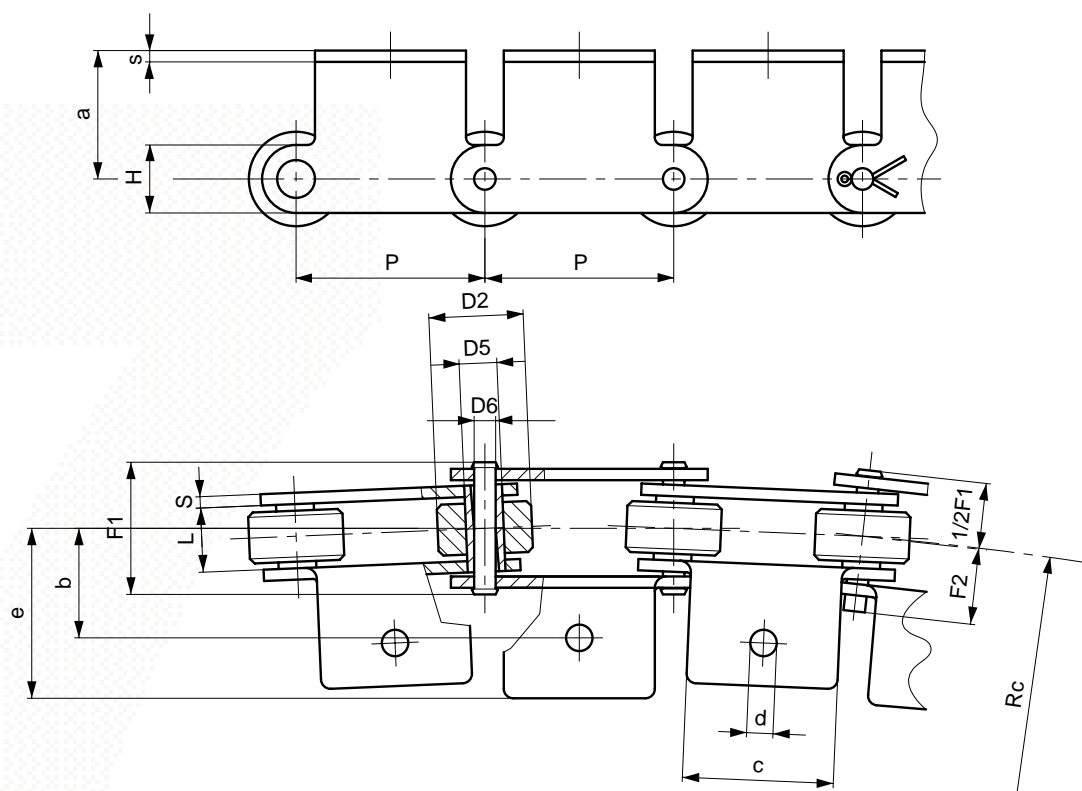

### A PERNI PIENI

Catena N.	P mm	L mm	D2 mm	D5 mm	D6 mm	H mm	S mm	F1 mm	F2 mm	** RC mm	Carico di rottura N	Peso cat. kg/m
C50	50	17	25	10	5,9	18	3	35	20	900	20.000	2,4
C65	65	17	25	10	5,9	18	3	35	20	1200	20.000	2

### ATTACCHI

Catena N.	P mm	a mm	b mm	c mm	d mm	e mm	s mm	Sovrapp. unit. attacco kg
C50	50	34	29	40	7	45	3	0,045
C30	65	34	29	50	7	43	3	0,055

\*\* RC raggio minimo di curvatura

